



# CITY OF APPLETON

## MEMORANDUM

**Date:** March 5, 2025  
**To:** Dean Gazza, Director of Parks, Recreation & Facilities Management  
Tom Flick, Deputy Director of Parks, Recreation & Facilities Management  
**From:** Lily Paul, Economic Development Specialist  
**Subject:** Creative Downtown Appleton, Inc. Selfie Sculpture Request

---

The Appleton Public Arts Committee met on March 5, 2025 and recommended approval of the request from Creative Downtown Appleton, Inc. to install a selfie sculpture within Houdini Plaza located at 121 W. College Avenue (Tax Id #31-2-0065-00) **as described in the attached documents and subject to the following conditions:**

1. An agreement between the applicant and the City will be prepared by the City's Legal Services Department and shall be executed prior to installation. This agreement will memorialize the expectations of the parties including the location of the art, installation and insurance requirements, maintenance, liability, indemnification, and the like.
2. Per the Art in Public Places Policy, any artwork signage shall meet the parameters set forth in Zoning Code Section 23-531(e), which allows each artwork one plaque/sign not to exceed nine square feet in size. Any proposed signs and their placement shall be approved by the Department of Public Works.
3. The applicant shall provide the Department of Parks & Recreation with a final placement of the sculpture prior to beginning the installation.

Per the Art in Public Places Policy, the recommendation from the Appleton Public Arts Committee is forwarded to the committee of jurisdiction, in this case, the Parks and Recreation Committee. This item will also be reviewed at City Plan Commission per Wis. State Statute 62.23(5) which states that the location of any statue or other memorial shall be referred to the Plan Commission for its consideration and report before final action is taken by the Common Council. Please place this item on the agenda for the March 10, 2025 Parks and Rec Committee meeting. Their recommendation would then be forwarded to the Common Council for consideration on March 19, 2025.

The staff memo prepared for the Public Arts Committee is attached as reference.



# CITY OF APPLETON

## MEMORANDUM

**Date:** March 5, 2025  
**To:** Public Arts Committee  
**From:** Lily Paul, Economic Development Specialist, Community Development Dept.  
**Subject:** Creative Downtown Appleton, Inc. Selfie Sculpture – Houdini Plaza

---

## GENERAL INFORMATION

**Applicant:** Creative Downtown Appleton, Inc. -- Jennifer Stephany, Executive Director of Appleton Downtown, Inc. (ADI)

**Address/Parcel Number:** Houdini Plaza, 121 W. College Avenue (Parcel #31-2-0065-00)

**Petitioner's Request:** Applicant is requesting to install an aluminum sculpture with photo opportunities in Houdini Plaza.

**Appleton Public Arts Committee Meeting Date:** March 5, 2025

**Parks and Recreation Committee Meeting Date:** March 10, 2025

**Plan Commission Meeting Date:** March 12, 2025

**Common Council Meeting Date:** March 19, 2025

---

## PROJECT DETAILS

**Project Summary:** Applicant is requesting to install a sculpture promoting Downtown Appleton within Houdini Plaza. The sculpture is being specifically designed and created to provide an interactive experience. The design is based around Appleton Downtown, Inc.'s "One Great Place" brand which features locator pins that will have cutouts perfect for photos! This sculpture is intended to be a focal point downtown.

**Reason for Choosing the Proposed Location:** The sculpture is proposed to be installed in Houdini Plaza which is a natural central meeting/gathering area within the downtown. This location makes sense with its intention of being a focal point. Specifically, within Houdini Plaza, the sculpture would be installed just south of the fountain, staying out of the right-of-way and far enough away from the lawn to avoid extra maintenance. This location has been pre-approved by the Parks & Recreation Department.

**Description of How the Work is Installed/Anchored/Attached:** The sculpture will be surface mounted to the concrete with concrete anchors.

**Timeline and Duration of Installation:** Once all approvals have been granted from the various committees, the fabrication of the sculpture will begin. The goal time for installation is by the 2025 NFL Draft, which is occurring in Green Bay on April 24-26.

**Maintenance and Cost:** City staff will have to remove snow around it, but snow removal is already performed in the right-of-way in Houdini Plaza, and this will add a small 12-foot section adjacent to the right-of-way. Also, the current method of snow removal is with a brush attachment which is effective for snow removal without having to do extra hand work.

**Associated Signage:** Per the Art in Public Places Policy, any artwork signage shall meet the parameters set forth in Zoning Code Section 23-531(e), which allows each artwork one plaque/sign not to exceed nine square feet in size. Any proposed signs and their placement shall be approved through the standard sign review process, if applicable.

**Appleton Comprehensive Plan 2010-2030:** The City of Appleton *Comprehensive Plan 2010-2030* illustrates the importance of the arts community to Appleton and encourages the expansion and promotion of placemaking and arts in the City. The proposed public art project is consistent with the following goals and objectives of the *Comprehensive Plan 2010-2030*.

*Chapter 3 – Community Vision #12: Creative place making and public art enhance the public realm and contribute to a vibrant economy.*

*Chapter 14 – Downtown Plan*

- *Strategy 1.4 Install sculpture, murals, and other art in public locations throughout the downtown*
- *Strategy 2.1 Maintain and strengthen the vitality of the arts and entertainment niche*

**Staff Comments:** A certificate of insurance from Appleton Downtown, Inc. will need to be filed if not already on file.

---

## **RECOMMENDATION**

Based upon the guidelines outlined in the Art in Public Places Policy, staff recommends that the proposed mural, located within Houdini Plaza, as described in the attached documents, **BE APPROVED** subject to the following conditions:

1. An agreement between the applicant and the City will be prepared by the City's Legal Services Department and shall be executed prior to installation. This agreement will memorialize the expectations of the parties including the location of the art, installation and insurance requirements, maintenance, liability, indemnification, and the like.
2. Per the Art in Public Places Policy, any artwork signage shall meet the parameters set forth in Zoning Code Section 23-531(e), which allows each artwork one plaque/sign not to exceed nine square feet in size. Any proposed signs and their placement shall be approved by the Department of Public Works.
3. The applicant shall provide the Department of Parks & Recreation with a final placement of the sculpture prior to beginning the installation.



**PUBLIC ART APPLICATION**  
 Community Development Department  
 100 N. Appleton St. PH: 920-832-6468  
 Appleton, WI 54911 FAX: 920-832-5994

Stamp date received

ARTIST / APPLICANT	
Name	* Creative Downtown Appleton Inc
Mailing Address	333 W College Ave Appleton WI 54911
Phone	920-954-9112
E-mail	Jennifer@appletondowntown.org

PROJECT AND LOCATION INFORMATION	
Property Tax # (31-0-0000-00) – if applicable	
Site Address/Location	Houdini Plaza
Description of proposed location for artwork within the property or facility (freestanding, attached to the building, inside building, etc.)	Freestanding metal sculpture anchored into the concrete
Project Title	One Great Place For...
Type of Artwork (mural, statue, sculpture, fountain, etc.)	Sculpture

SUBMITTAL REQUIREMENTS	
A complete submittal includes a completed application signed by the applicant with the following supplementary information:	
<ul style="list-style-type: none"> <li>• Brief description of the proposed artwork</li> <li>• Photos/sketches of proposed work</li> <li>• Site plan/location map showing location of proposed work</li> <li>• Reason for choosing the proposed location</li> <li>• Description of how the work is installed/anchored/attached</li> <li>• Installation specifications provided by a structural engineer</li> <li>• Timeline and duration of installation</li> <li>• How the artwork will be maintained (including any costs associated with the maintenance and who will be responsible for those costs)</li> <li>• Description of any associated signage</li> </ul>	

SIGNATURE	
2-19-25	<i>Jennifer Stigman</i>
Date	Applicant/Artist Signature

OFFICE USE ONLY	
Application Complete _____	Date Filed ____/____/____

**A complete submittal includes a completed application signed by the applicant with the following supplementary information:**

**• Brief description of the proposed artwork**

This proposal outlines the creation and installation of a large-scale, interactive sculpture featuring the One Great Place locator pin. This piece will serve as a vibrant focal point in Downtown, strengthening the One Great Place brand, celebrating the district as a destination for a variety of experiences, fostering community belonging, and organically driving social media content.

The proposed design image is attached and will be constructed out of plate aluminum by sculptor Rob Neilson, Frederick R. Layton Professor of Studio Art and Professor of Art. Rob has created large scale work for many installations including the Fox Cities Exhibition Center.

The smaller locator pins will each be a different color pulled from our One Great Place logo: blue, purple, orange, yellow, green – our PMI colors are attached.

The base would be dark gray or black and will read... One Great Place for...

The colored locator pins will include interchangeable words that CDA could on occasion change out. They will be bolted to the piece. The intent is to have it read: One Great place for... Unique Shops, Tasty Treats, Dining, Live Music, Art, Museums, Urban Living, The Holidays, Parades, Octoberfest, Mile of Music etc... we are also open to words the City would like to include.

We would like permission to externally light the sculpture with small LED flood lights as shown below. This will be added at a later date as we work with Park and Recreation to determine access for power. All costs associated with access would be the responsibility of CDA.

- The sculpture size is 12 feet long, 7 feet high and 3.5 to 4 feet wide
- Material is plate aluminum
- Colors proposed as attached.

**• Site plan/location map showing location of proposed work**

The proposed location is Houdini Plaza east side of the grass set on the concrete as indicated on the attached images of Houdini Plaza. We have worked with Park and Recreation Deputy Director Tom Flick to identify this proposed site and will continue to collaborate with the staff on installation.

**• Reason for choosing the proposed location:**

This location was selected on account of its central location, high visibility and public access to interact with the sculpture. Additionally, potential access to a power source to externally light the sign which we would work with DPW and Park and Recreation to coordinate. Any associate expense would be CDAs responsibility.

**• Description of how the work is installed/anchored/attached**

Rob is proposing that a metal mounting plate be anchored into the concrete with bolts. The sculpture would bolt to the mounting plate

**• Installation specifications provided by a structural engineer**

Rob will be working with Daniel J. Brellen P.E., LEED AP at McMahon for the structural engineering drawings and installation. We will have engineering drawings within one week before the meeting.

**• Timeline and duration of installation**

We are proposing that the sculpture be placed for a duration of one year, with an option to apply for a continuation. We would have the sculpture inspected prior to approval.

**Proposed Timeline for approval:**

- Public Art Committee – 3/5
- Park and Recreation – 3/10
- Planning Commission – 3/12
- City Council – 3/19
- Installation 4/21 – 4/22

**• How the artwork will be maintained (including any costs associated with the maintenance and who will be responsible for those costs)**

The sculpture will be maintained by CDA. We will contract with Rob Neilson to do any repairs associated with damage. Having the annual inspection and approval would also allow the City to request any additional modifications. We will include \$1000 in our annual budget for maintenance.

**• Description of any associated signage**

Attached to the sculpture would be the Downtown locator pin logo as indicated on the image. No additional signage is proposed at this time.

**Other items?**



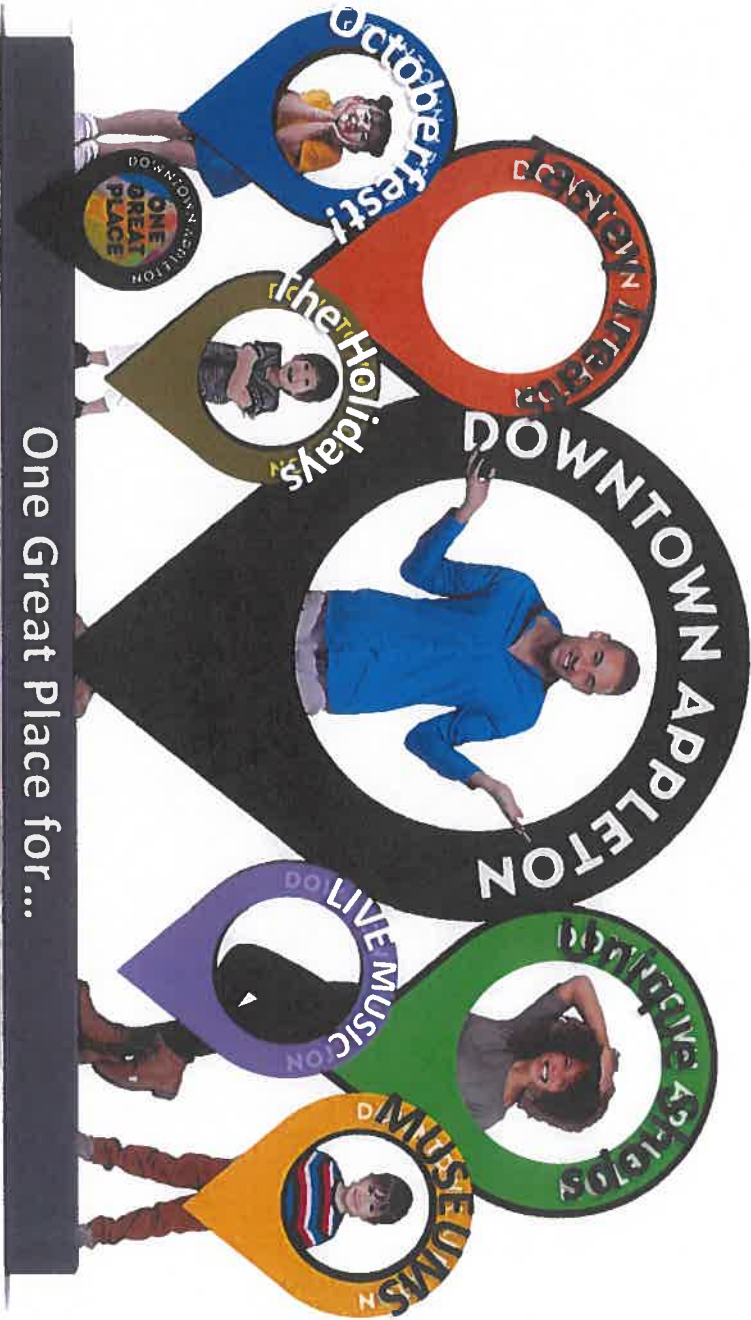

APPROXIMATE SCALE

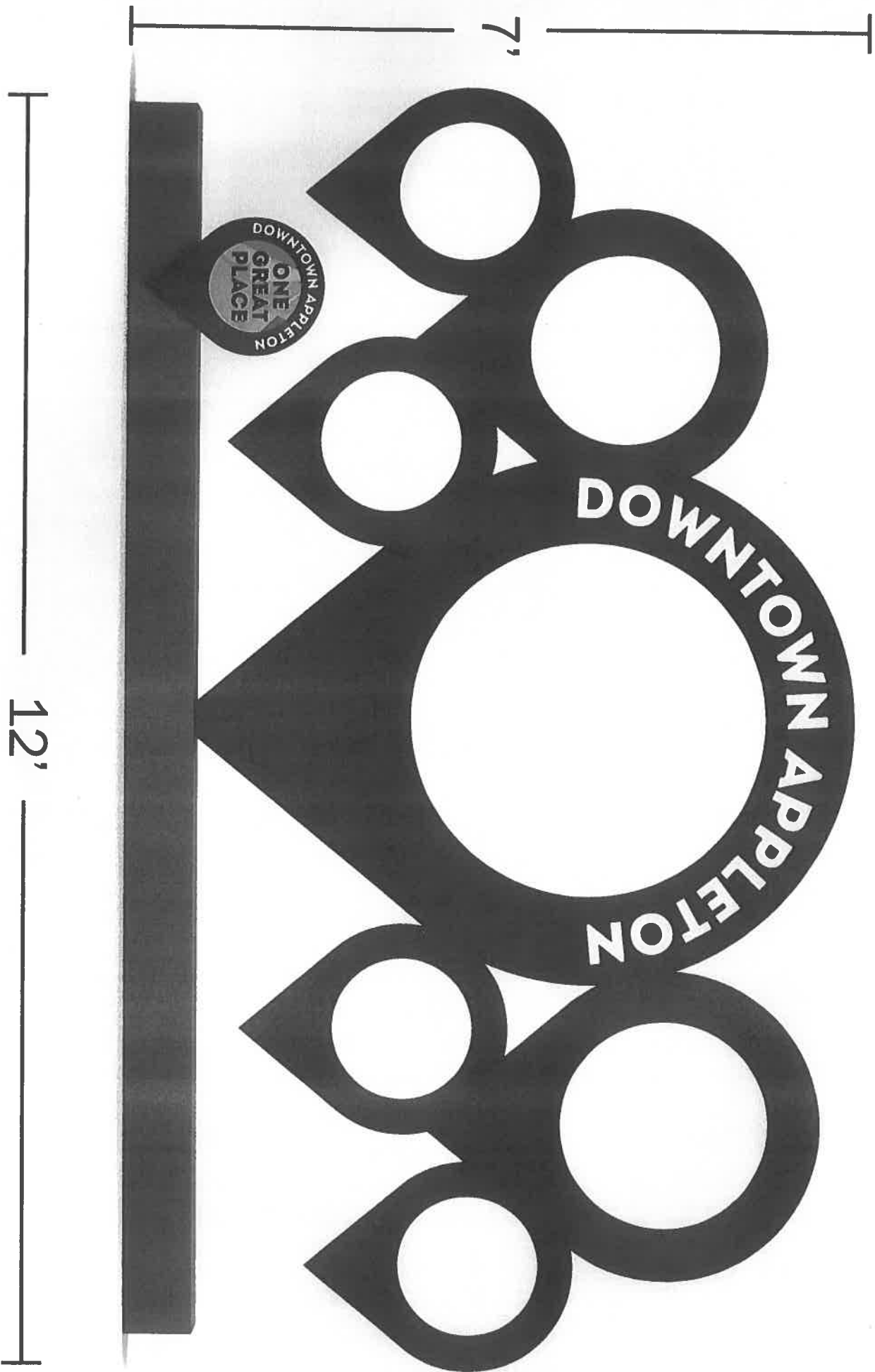



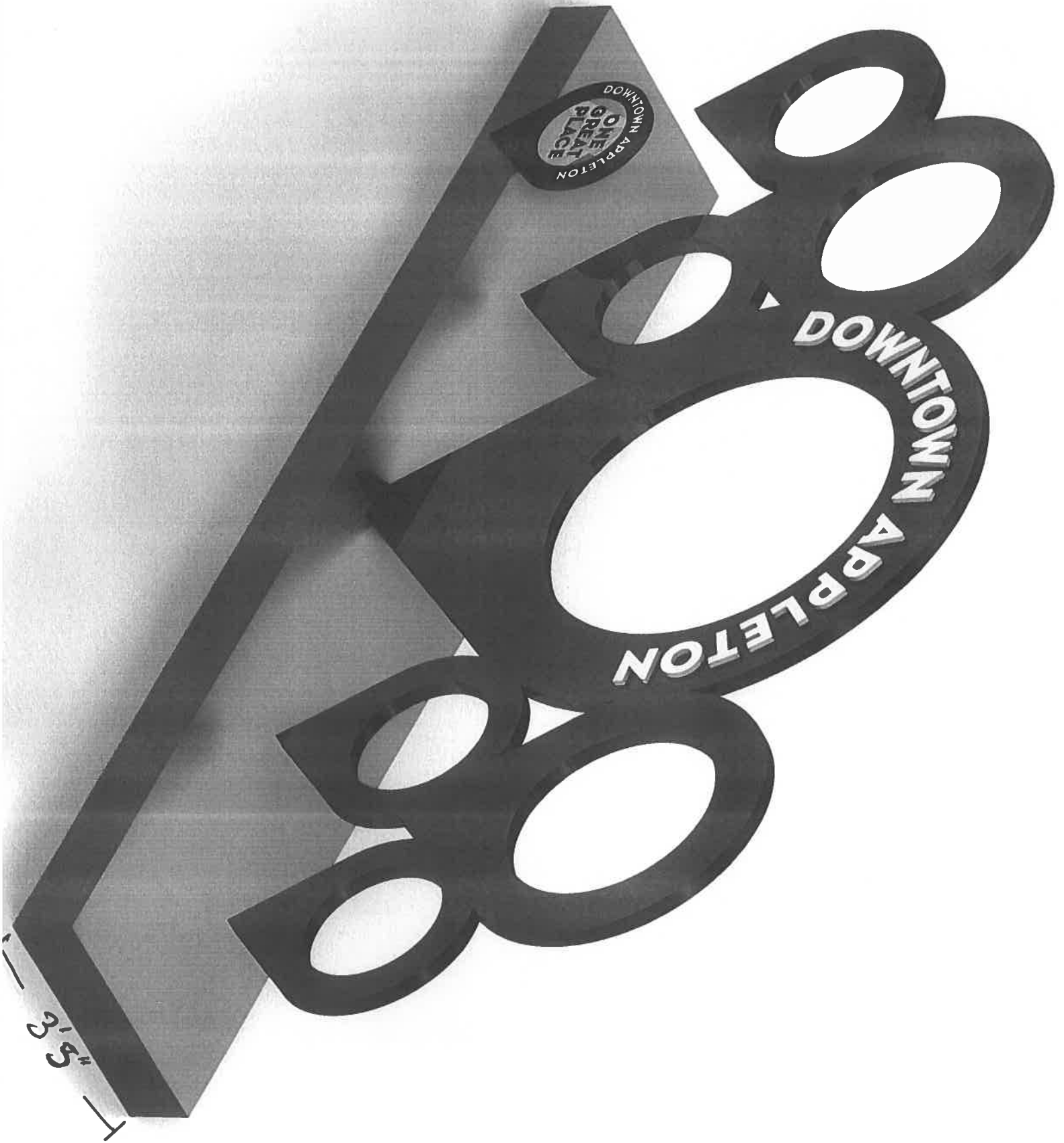

3 1/2"



# POSSIBLE MATERIAL

Raised Letters

.75" Thick Painted  
Plate Aluminum

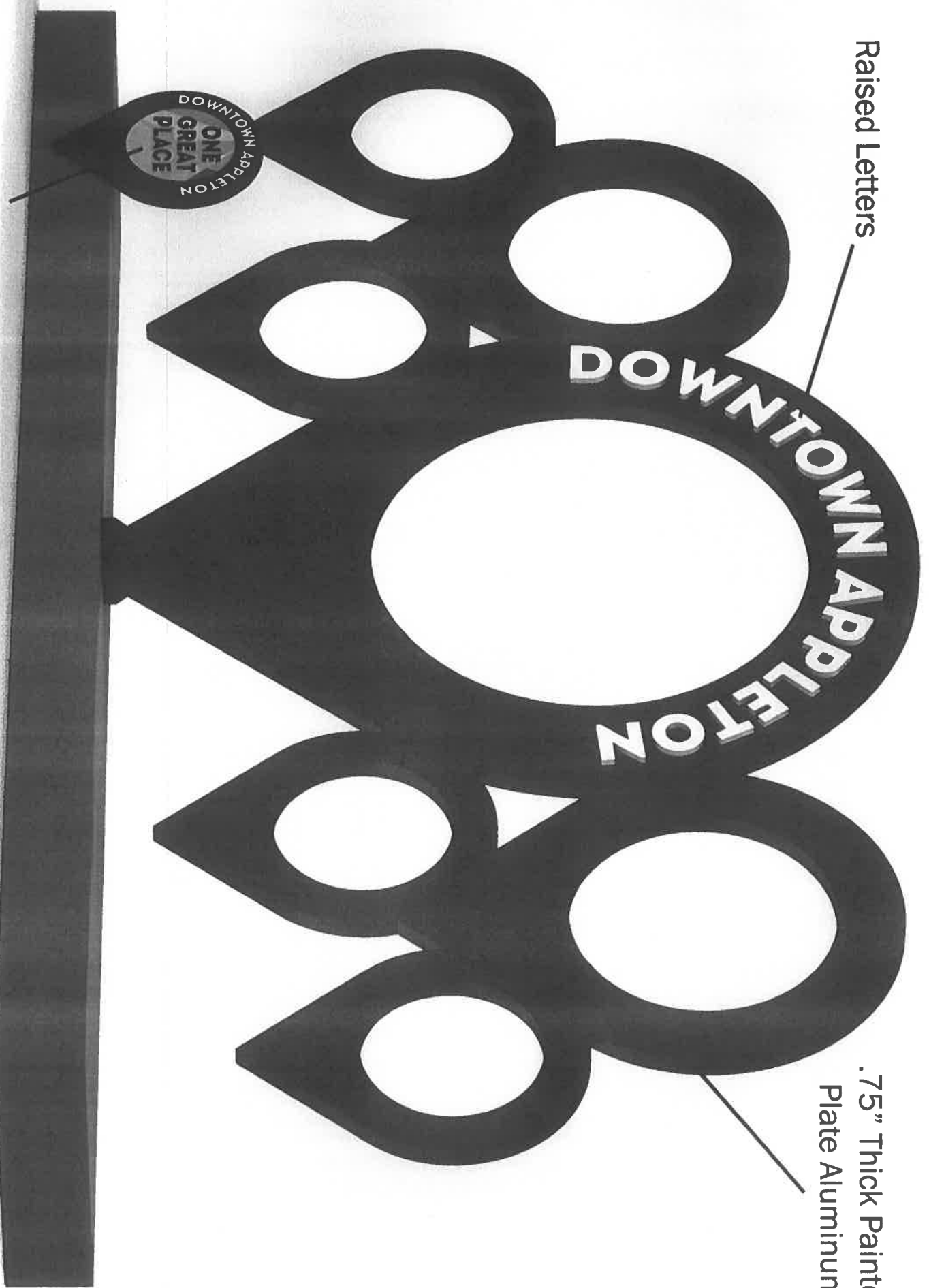

Industrial Decal Atop Plate Aluminum







# HOUDINI PLAZA

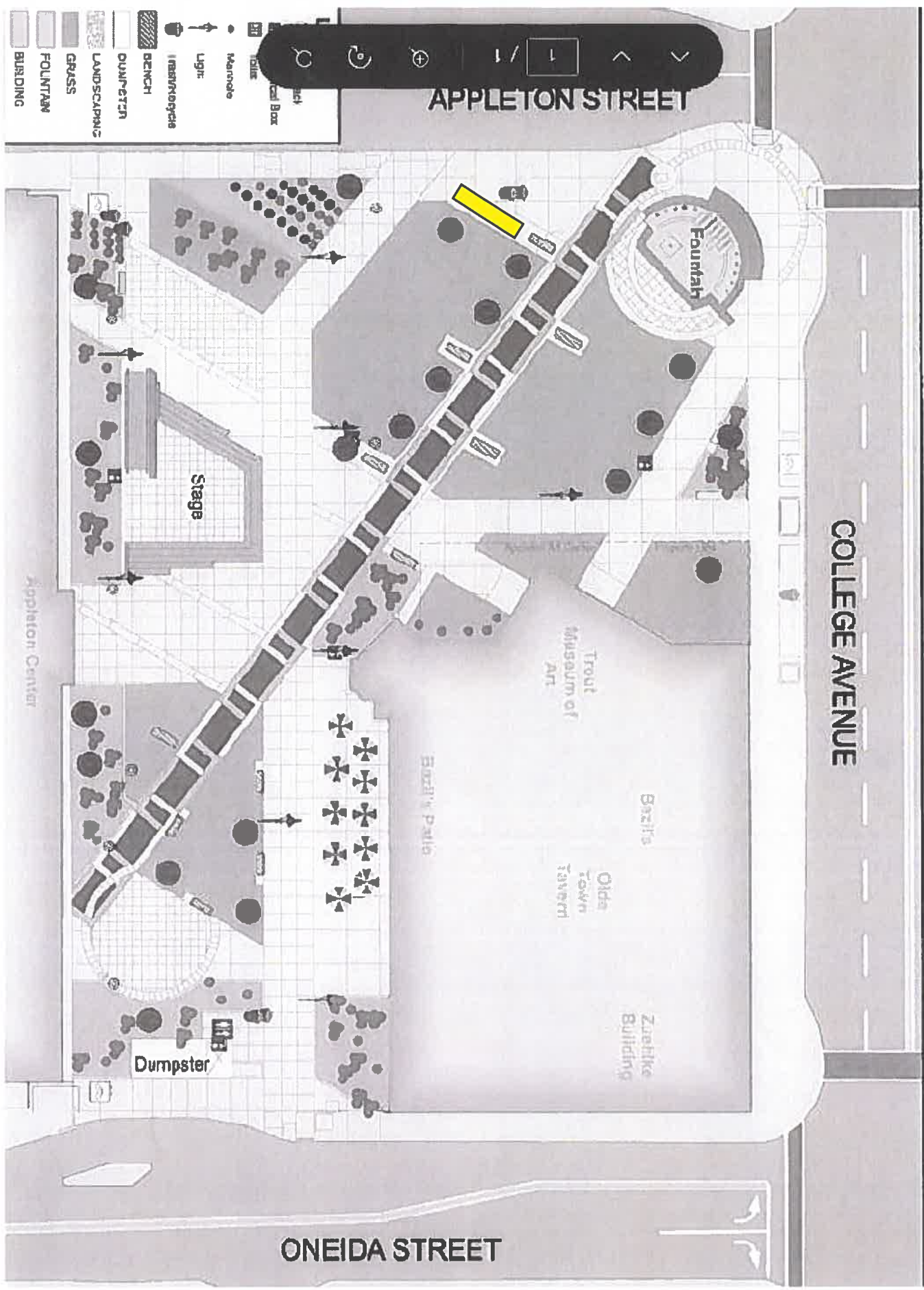

- BUILDING
- FOUNTAIN
- GRASS
- LANDSCAPING
- QUERCUS
- BENCH
- Irrigation
- Light
- Manhole
- Trench
- Electrical Box

APPLETON STREET

COLLEGE AVENUE

ONEIDA STREET

Stage

Fountain

Trout  
Museum of  
Art

Brazis

Olds  
Town  
Tavern

Zuelke  
Building

Brazis  
patio

Dumpster

Appleton Center

## DOWNTOWN BRIGHTS COLOR PALETTE



**BLUE**  
CMYK: 100, 20, 0, 0  
RGB: 0, 149, 218



**YELLOW**  
CMYK: 0, 20, 100, 0  
RGB: 255, 203, 5



**GREEN**  
CMYK: 50, 0, 100, 0  
RGB: 141, 198, 63



**DEEP TEAL**  
CMYK: 50, 100, 0, 0  
RGB: 146, 39, 143



**RED**  
CMYK: 0, 90, 65, 0  
RGB: 239, 64, 80



**ORANGE**  
CMYK: 0, 70, 100, 0  
RGB: 243, 112, 33



**MAGENTA**  
CMYK: 0, 90, 0, 0  
RGB: 238, 61, 150



**BLACK**  
CMYK: 0, 0, 0, 100  
RGB: 0, 0, 0



**RICH BLACK**  
CMYK: 30, 30, 30, 100  
RGB: 0, 0, 0



**WHITE**  
CMYK: 0, 0, 0, 0  
RGB: 255, 255, 255



GREAT FOOD

DOWNTOWN APPLETON

BEER

GREAT ART

FRIENDLY FOLKS

FAMILY FUN

MUSIC

DOWNTOWN APPLETON  
ONE GREAT PLACE

I'M HERE FOR THE...





GREAT FOOD

DOWNTOWN APPLETON

BEER

MUSIC

FAMILY FUN

FRIENDLY FOLKS

GREAT ART

DOWNTOWN APPLETON  
ONE GREAT PLACE

I'M HERE FOR THE...







# EXPLODED VIEW SCULPTURE



PAINTED PLATE  
ALUMINUM 1/4"

ONE PIECE PAINTED PLATE ALUMINUM 3/4"

GREAT FOOD

GREAT ART

FRIENDLY FOLKS

BOLTS FOR ATTACHING TO  
LARGE CLACK CENTER "PIN"

INDUSTRIAL DECAL

INDUSTRIAL DECAL

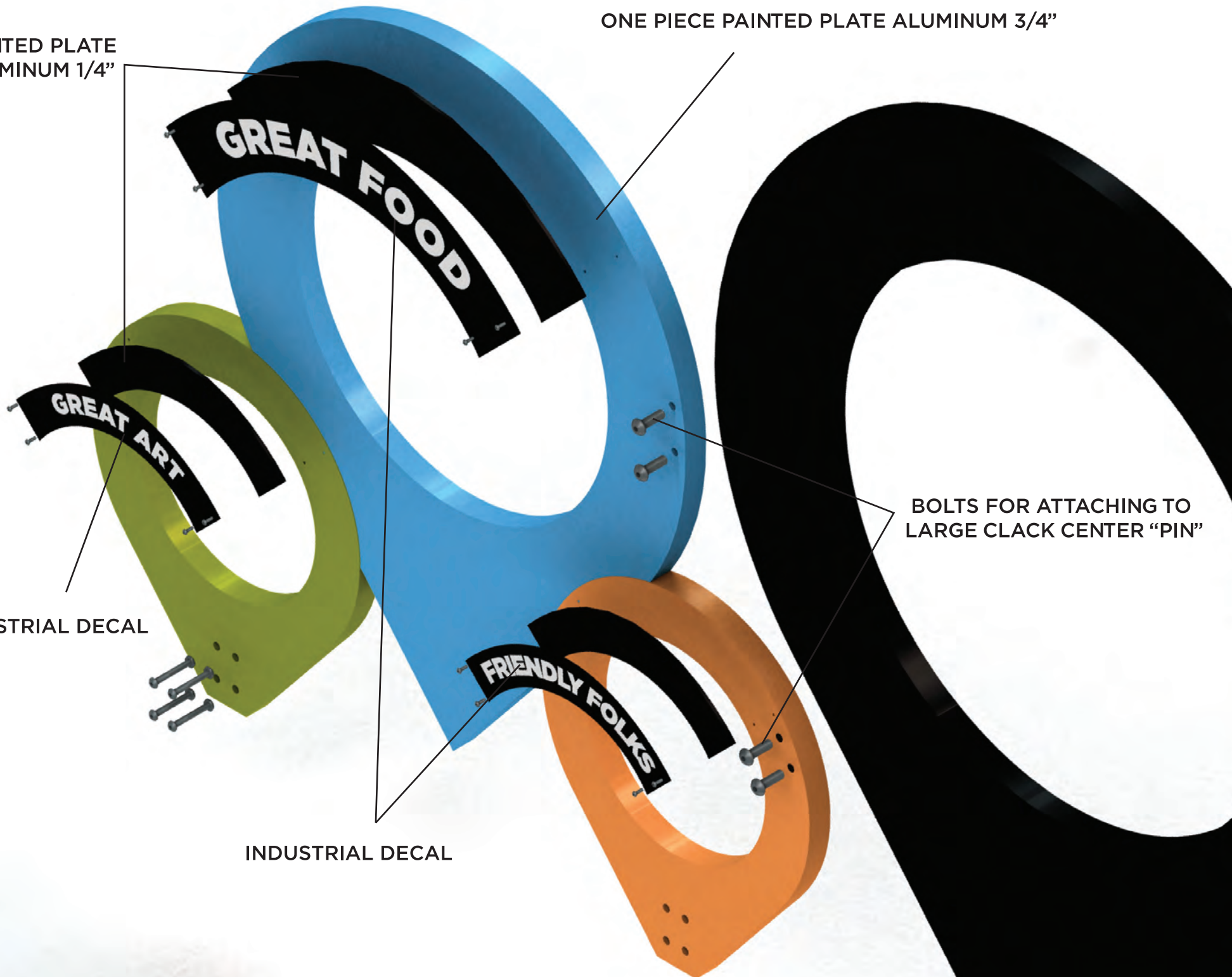

INDUSTRIAL DECAL

PAINTED PLATE ALUMINUM 3/4"



FABRICATED BRACKETS  
ALUMINUM 1/4"



PAINTED PLATE ALUMINUM 1/4"

PAINTED PLATE  
ALUMINUM 1/4"

INDUSTRIAL DECAL

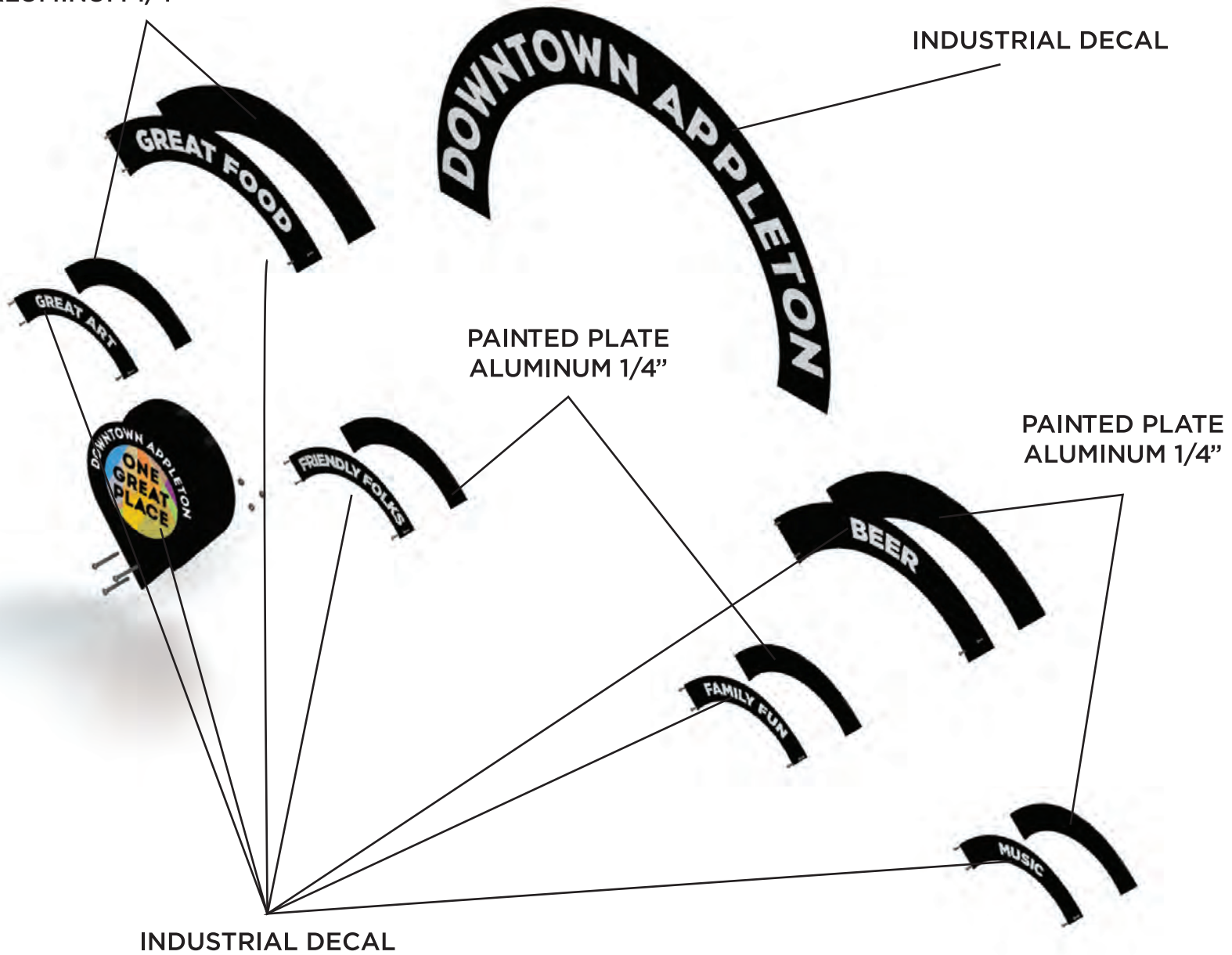

PAINTED PLATE ALUMINUM 3/4"

ONE PIECE  
PAINTED  
TO LOOK  
LIKE THREE

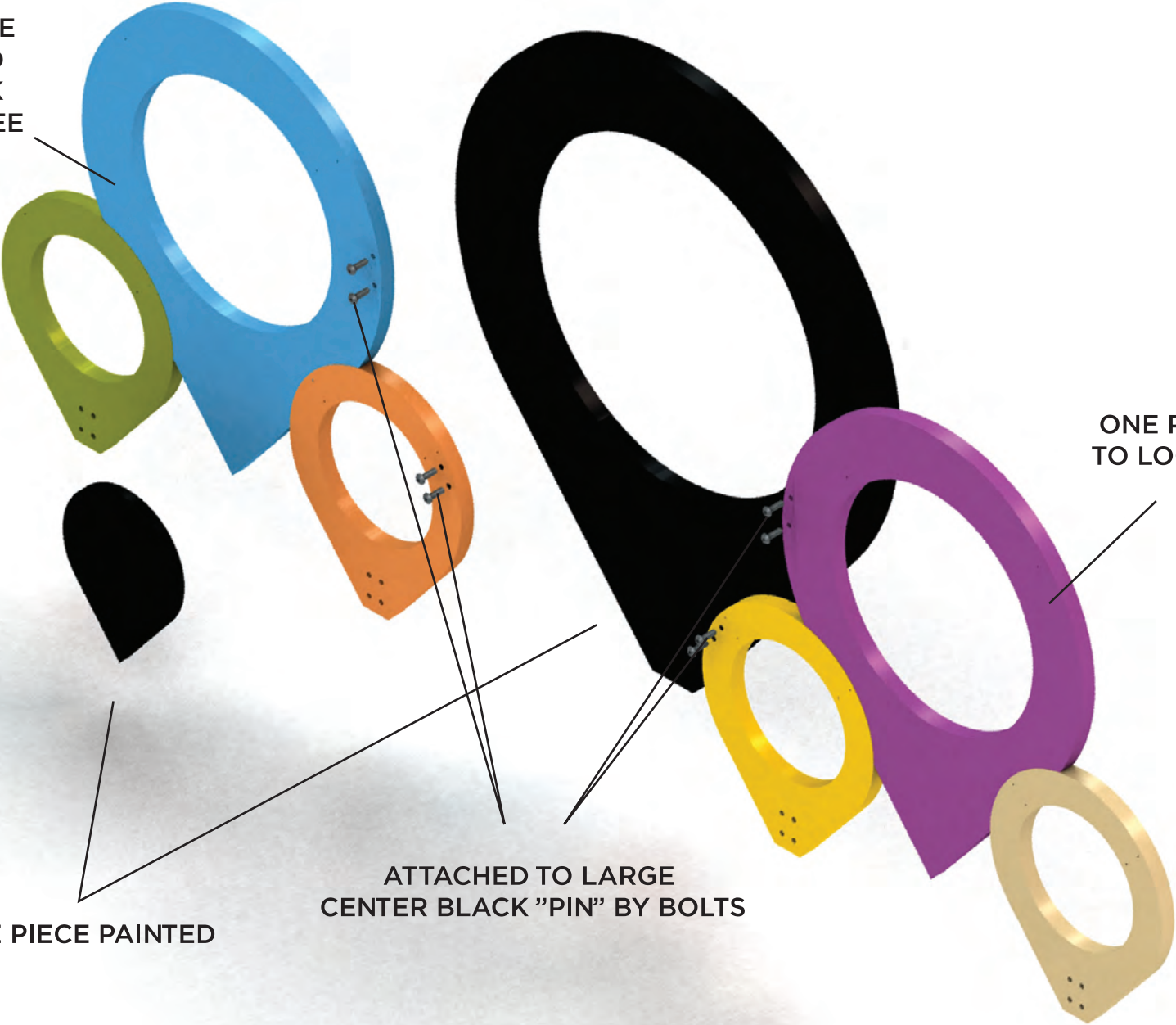

ONE PIECE PAINTED  
TO LOOK LIKE THREE

ONE PIECE PAINTED

ATTACHED TO LARGE  
CENTER BLACK "PIN" BY BOLTS



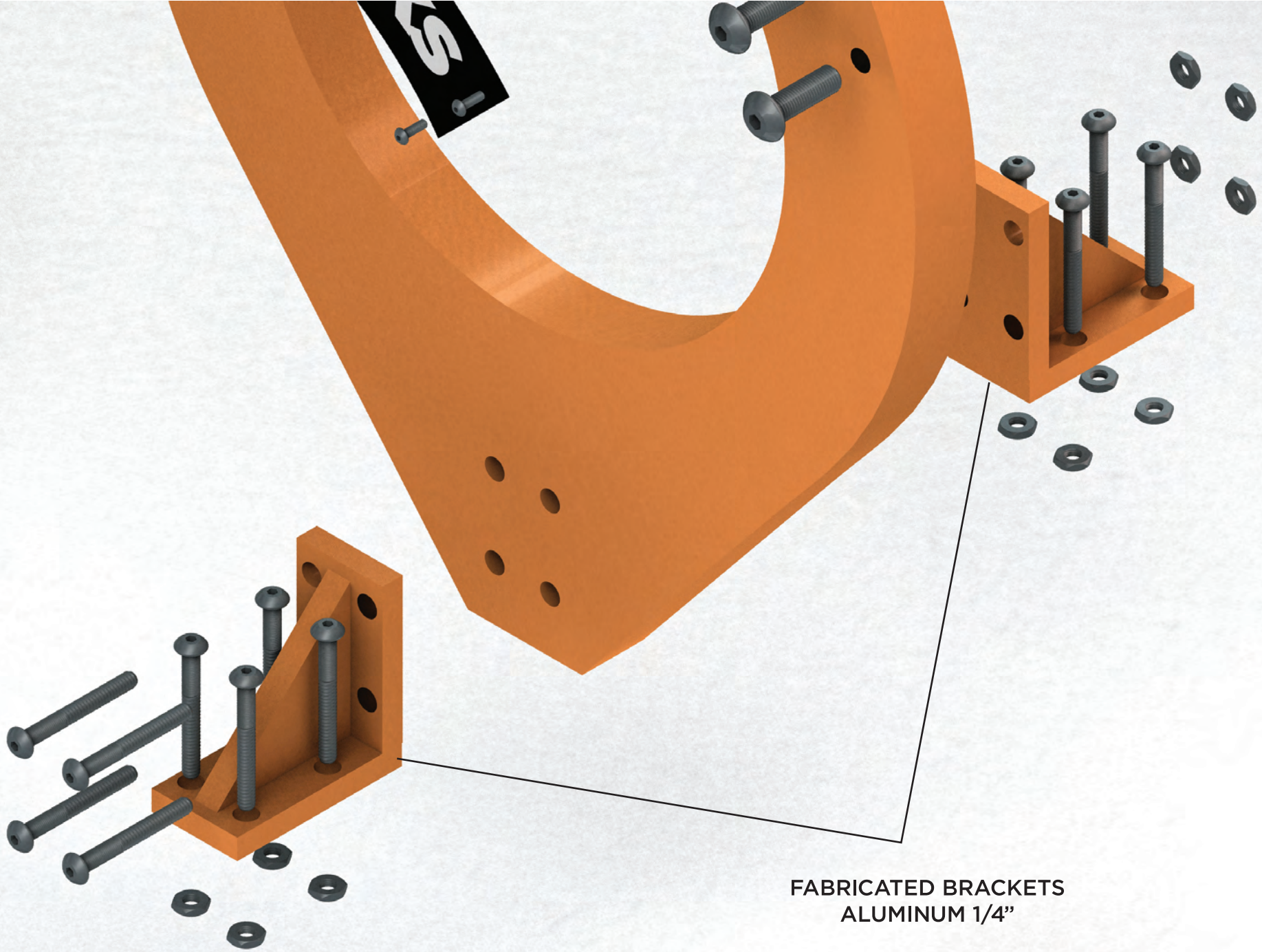

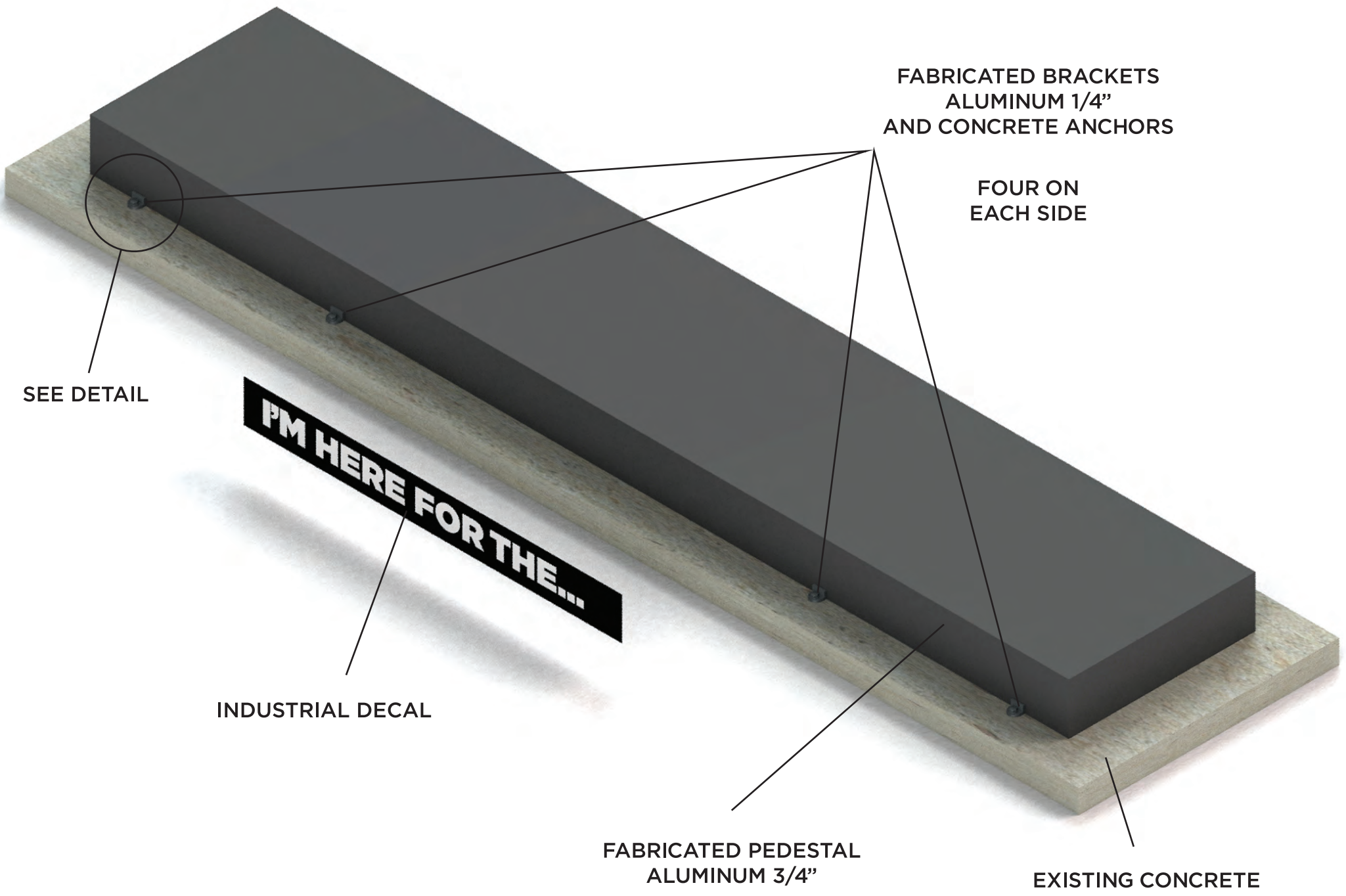

FABRICATED BRACKETS  
ALUMINUM 1/4"  
AND CONCRETE ANCHORS

FOUR ON  
EACH SIDE

SEE DETAIL

I'M HERE FOR THE...

INDUSTRIAL DECAL

FABRICATED PEDESTAL  
ALUMINUM 3/4"

EXISTING CONCRETE



1/2" x 5-1/2" Red Head Trubolt  
Hot-Dipped Galvanized

FABRICATED BRACKETS  
ALUMINUM 1/4"  
AND CONCRETE ANCHORS

WELDED  
TO PEDESTAL

EXISTING CONCRETE

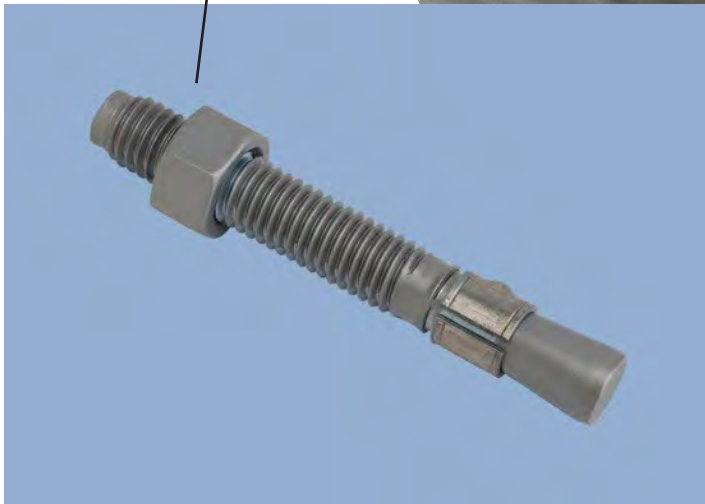
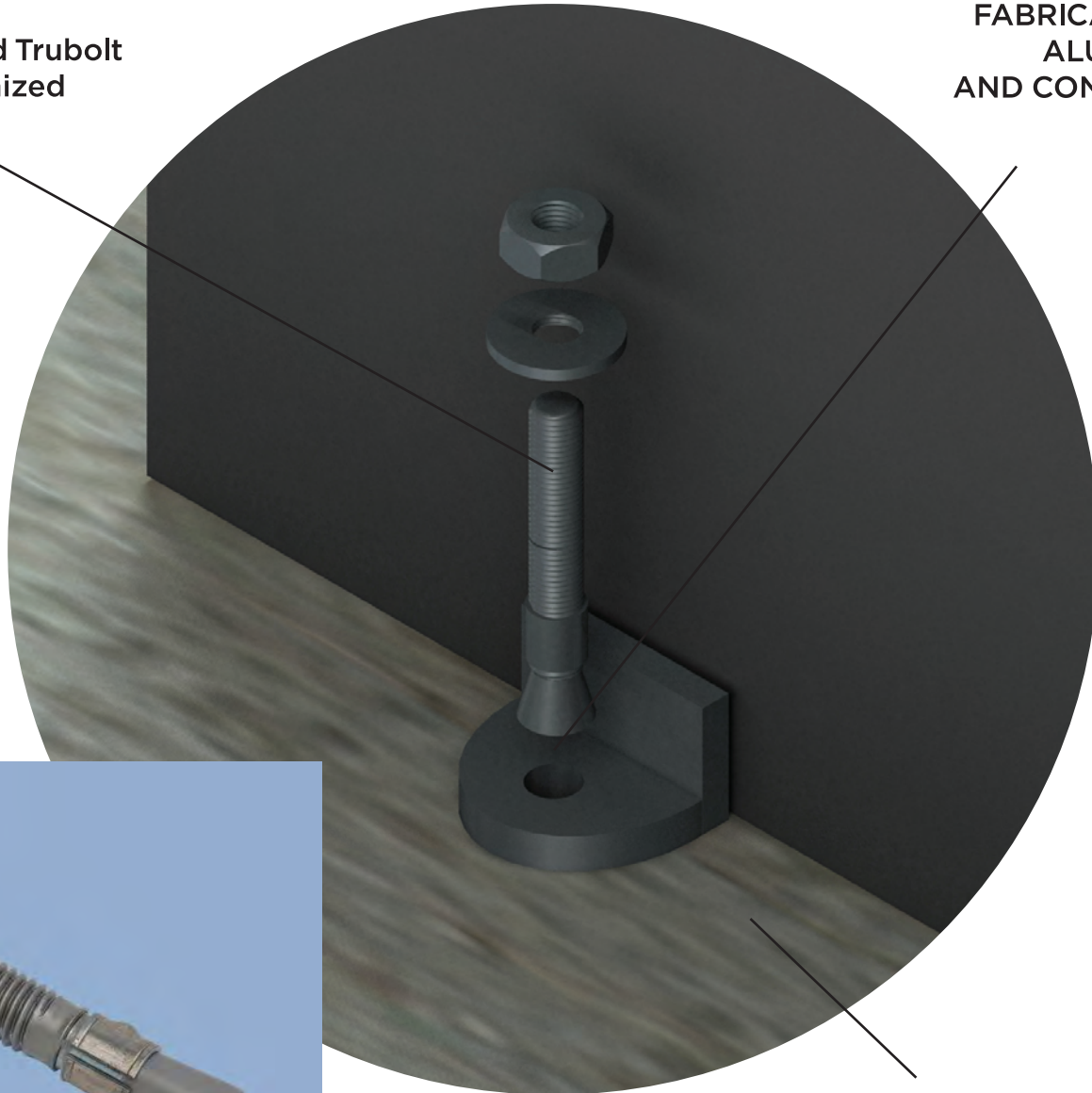

SCALE

