



City of Appleton

100 North Appleton Street
Appleton, WI 54911-4799
www.appletonwi.gov

Meeting Agenda - Final Appleton Public Arts Committee

Wednesday, March 5, 2025

8:00 AM

Council Chambers, 6th Floor

1. Call meeting to order
2. Pledge of Allegiance
3. Roll call of membership
4. Approval of minutes from previous meeting
[25-0181](#) APAC Minutes from 6-5-24
Attachments: [APAC Minutes from 6-5-24.pdf](#)
5. **Public Hearing/Appearances**
[25-0182](#) Public Participation
6. **Action Items**
[25-0183](#) Request from Creative Downtown Appleton, Inc. to install a selfie sculpture on City-owned property located within Houdini Plaza at 121 W. College Avenue (Tax Id #31-2-0065-00) as described in the attached documents and subject to the conditions in the attached staff memo
Attachments: [ADI Selfie Sculpture Memo to APAC 03-05-25.pdf](#)
7. **Information Items**
[25-0184](#) Presentation of Creative Community Champion Award by Mayor Woodford
[25-0185](#) Resignation of Catherine McKenzie and New Appointment of Jake Bauer
Attachments: [25-0041 - APA Appt Memo 2-5-2025.pdf](#)

8. Adjournment

Notice is hereby given that a quorum of the Common Council may be present during this meeting, although no Council action will be taken.

Any questions about items on this meeting are to be directed to Kara Homan, Director, Community Development Department at 920-832-6468.

Reasonable Accommodations for Persons with Disabilities will be made upon Request and if Feasible.



City of Appleton

100 North Appleton Street
Appleton, WI 54911-4799
www.appleton.org

Meeting Minutes - Final Appleton Public Arts Committee

Wednesday, June 5, 2024

8:00 AM

Council Chambers, 6th Floor

1. Call meeting to order

Vice Chair Vang called the meeting to order at 8:02 a.m.

2. Pledge of Allegiance

3. Roll call of membership

Hoekstra appeared virtually and participated via Zoom.

Present: 5 - McKenzie, Fernandez, Vang, Hoekstra and Laste

Excused: 2 - Riesterer and Mische

4. Approval of minutes from previous meeting

[24-0696](#)

APAC Minutes from 5-8-24

Attachments: [APAC Minutes 5-8-24.pdf](#)

McKenzie moved, seconded by Fernandez, that the Minutes be approved. Roll Call. Motion carried by the following vote:

Aye: 5 - McKenzie, Fernandez, Vang, Hoekstra and Laste

Excused: 2 - Riesterer and Mische

5. Public Hearing/Appearances

[24-0697](#)

Public Participation

There was no public participation.

6. Action Items

[24-0698](#)

Request from the Appleton Police Department to paint a mural to be located on the east-facing concrete wall, between the lower garage and the upper parking deck, located at 222 S. Walnut Street (Tax Id #31-3-0840-00) as described in the attached documents and subject to the conditions in the attached staff memo

Attachments: [StaffMemo_PDMural_For6-5-24.pdf](#)

Laste moved, seconded by McKenzie, that the proposal to paint a mural located at the Appleton Police Department be approved. Roll Call. Motion carried by the following vote:

Aye: 5 - McKenzie, Fernandez, Vang, Hoekstra and Laste

Excused: 2 - Riesterer and Mische

7. Information Items

8. Adjournment

McKenzie moved, seconded by Laste, that the meeting be adjourned at 8:14 a.m. Roll Call. Motion carried by the following vote:

Aye: 5 - McKenzie, Fernandez, Vang, Hoekstra and Laste

Excused: 2 - Riesterer and Mische



CITY OF APPLETON

MEMORANDUM

Date: March 5, 2025
To: Public Arts Committee
From: Lily Paul, Economic Development Specialist, Community Development Dept.
Subject: Creative Downtown Appleton, Inc. Selfie Sculpture – Houdini Plaza

GENERAL INFORMATION

Applicant: Creative Downtown Appleton, Inc. -- Jennifer Stephany, Executive Director of Appleton Downtown, Inc. (ADI)

Address/Parcel Number: Houdini Plaza, 121 W. College Avenue (Parcel #31-2-0065-00)

Petitioner's Request: Applicant is requesting to install an aluminum sculpture with photo opportunities in Houdini Plaza.

Appleton Public Arts Committee Meeting Date: March 5, 2025

Parks and Recreation Committee Meeting Date: March 10, 2025

Plan Commission Meeting Date: March 12, 2025

Common Council Meeting Date: March 19, 2025

PROJECT DETAILS

Project Summary: Applicant is requesting to install a sculpture promoting Downtown Appleton within Houdini Plaza. The sculpture is being specifically designed and created to provide an interactive experience. The design is based around Appleton Downtown, Inc.'s "One Great Place" brand which features locator pins that will have cutouts perfect for photos! This sculpture is intended to be a focal point downtown.

Reason for Choosing the Proposed Location: The sculpture is proposed to be installed in Houdini Plaza which is a natural central meeting/gathering area within the downtown. This location makes sense with its intention of being a focal point. Specifically, within Houdini Plaza, the sculpture would be installed just south of the fountain, staying out of the right-of-way and far enough away from the lawn to avoid extra maintenance. This location has been pre-approved by the Parks & Recreation Department.

Description of How the Work is Installed/Anchored/Attached: The sculpture will be surface mounted to the concrete with concrete anchors.

Timeline and Duration of Installation: Once all approvals have been granted from the various committees, the fabrication of the sculpture will begin. The goal time for installation is by the 2025 NFL Draft, which is occurring in Green Bay on April 24-26.

Maintenance and Cost: City staff will have to remove snow around it, but snow removal is already performed in the right-of-way in Houdini Plaza, and this will add a small 12-foot section adjacent to the right-of-way. Also, the current method of snow removal is with a brush attachment which is effective for snow removal without having to do extra hand work.

Associated Signage: Per the Art in Public Places Policy, any artwork signage shall meet the parameters set forth in Zoning Code Section 23-531(e), which allows each artwork one plaque/sign not to exceed nine square feet in size. Any proposed signs and their placement shall be approved through the standard sign review process, if applicable.

Appleton Comprehensive Plan 2010-2030: The City of Appleton *Comprehensive Plan 2010-2030* illustrates the importance of the arts community to Appleton and encourages the expansion and promotion of placemaking and arts in the City. The proposed public art project is consistent with the following goals and objectives of the *Comprehensive Plan 2010-2030*.

Chapter 3 – Community Vision #12: Creative place making and public art enhance the public realm and contribute to a vibrant economy.

Chapter 14 – Downtown Plan

- *Strategy 1.4 Install sculpture, murals, and other art in public locations throughout the downtown*
- *Strategy 2.1 Maintain and strengthen the vitality of the arts and entertainment niche*

Staff Comments: A certificate of insurance from Appleton Downtown, Inc. will need to be filed if not already on file.

RECOMMENDATION

Based upon the guidelines outlined in the Art in Public Places Policy, staff recommends that the proposed mural, located within Houdini Plaza, as described in the attached documents, **BE APPROVED** subject to the following conditions:

1. An agreement between the applicant and the City will be prepared by the City's Legal Services Department and shall be executed prior to installation. This agreement will memorialize the expectations of the parties including the location of the art, installation and insurance requirements, maintenance, liability, indemnification, and the like.
2. Per the Art in Public Places Policy, any artwork signage shall meet the parameters set forth in Zoning Code Section 23-531(e), which allows each artwork one plaque/sign not to exceed nine square feet in size. Any proposed signs and their placement shall be approved by the Department of Public Works.
3. The applicant shall provide the Department of Parks & Recreation with a final placement of the sculpture prior to beginning the installation.



PUBLIC ART APPLICATION
 Community Development Department
 100 N. Appleton St. PH: 920-832-6468
 Appleton, WI 54911 FAX: 920-832-5994

Stamp date received

ARTIST / APPLICANT	
Name	* Creative Downtown Appleton Inc
Mailing Address	333 W College Ave Appleton WI 54911
Phone	920-954-9112
E-mail	Jennifer@appletondowntown.org

PROJECT AND LOCATION INFORMATION	
Property Tax # (31-0-0000-00) – if applicable	
Site Address/Location	Houdini Plaza
Description of proposed location for artwork within the property or facility (freestanding, attached to the building, inside building, etc.)	Freestanding metal sculpture anchored into the concrete
Project Title	One Great Place For...
Type of Artwork (mural, statue, sculpture, fountain, etc.)	Sculpture

SUBMITTAL REQUIREMENTS	
A complete submittal includes a completed application signed by the applicant with the following supplementary information:	
<ul style="list-style-type: none"> • Brief description of the proposed artwork • Photos/sketches of proposed work • Site plan/location map showing location of proposed work • Reason for choosing the proposed location • Description of how the work is installed/anchored/attached • Installation specifications provided by a structural engineer • Timeline and duration of installation • How the artwork will be maintained (including any costs associated with the maintenance and who will be responsible for those costs) • Description of any associated signage 	

SIGNATURE	
2-19-25	<i>Jennifer Stuyvesant</i>
Date	Applicant/Artist Signature

OFFICE USE ONLY	
Application Complete _____	Date Filed ____/____/____

A complete submittal includes a completed application signed by the applicant with the following supplementary information:

• Brief description of the proposed artwork

This proposal outlines the creation and installation of a large-scale, interactive sculpture featuring the One Great Place locator pin. This piece will serve as a vibrant focal point in Downtown, strengthening the One Great Place brand, celebrating the district as a destination for a variety of experiences, fostering community belonging, and organically driving social media content.

The proposed design image is attached and will be constructed out of plate aluminum by sculptor Rob Neilson, Frederick R. Layton Professor of Studio Art and Professor of Art. Rob has created large scale work for many installations including the Fox Cities Exhibition Center.

The smaller locator pins will each be a different color pulled from our One Great Place logo: blue, purple, orange, yellow, green – our PMI colors are attached.

The base would be dark gray or black and will read... One Great Place for...

The colored locator pins will include interchangeable words that CDA could on occasion change out. They will be bolted to the piece. The intent is to have it read: One Great place for... Unique Shops, Tasty Treats, Dining, Live Music, Art, Museums, Urban Living, The Holidays, Parades, Octoberfest, Mile of Music etc... we are also open to words the City would like to include.

We would like permission to externally light the sculpture with small LED flood lights as shown below. This will be added at a later date as we work with Park and Recreation to determine access for power. All costs associated with access would be the responsibility of CDA.

- The sculpture size is 12 feet long, 7 feet high and 3.5 to 4 feet wide
- Material is plate aluminum
- Colors proposed as attached.

• Site plan/location map showing location of proposed work

The proposed location is Houdini Plaza east side of the grass set on the concrete as indicated on the attached images of Houdini Plaza. We have worked with Park and Recreation Deputy Director Tom Flick to identify this proposed site and will continue to collaborate with the staff on installation.

• Reason for choosing the proposed location:

This location was selected on account of its central location, high visibility and public access to interact with the sculpture. Additionally, potential access to a power source to externally light the sign which we would work with DPW and Park and Recreation to coordinate. Any associate expense would be CDAs responsibility.

• **Description of how the work is installed/anchored/attached**

Rob is proposing that a metal mounting plate be anchored into the concrete with bolts. The sculpture would bolt to the mounting plate

• **Installation specifications provided by a structural engineer**

Rob will be working with Daniel J. Brellen P.E., LEED AP at McMahon for the structural engineering drawings and installation. We will have engineering drawings within one week before the meeting.

• **Timeline and duration of installation**

We are proposing that the sculpture be placed for a duration of one year, with an option to apply for a continuation. We would have the sculpture inspected prior to approval.

Proposed Timeline for approval:

- Public Art Committee – 3/5
- Park and Recreation – 3/10
- Planning Commission – 3/12
- City Council – 3/19
- Installation 4/21 – 4/22

• **How the artwork will be maintained (including any costs associated with the maintenance and who will be responsible for those costs)**

The sculpture will be maintained by CDA. We will contract with Rob Neilson to do any repairs associated with damage. Having the annual inspection and approval would also allow the City to request any additional modifications. We will include \$1000 in our annual budget for maintenance.

• **Description of any associated signage**

Attached to the sculpture would be the Downtown locator pin logo as indicated on the image. No additional signage is proposed at this time.

Other items?



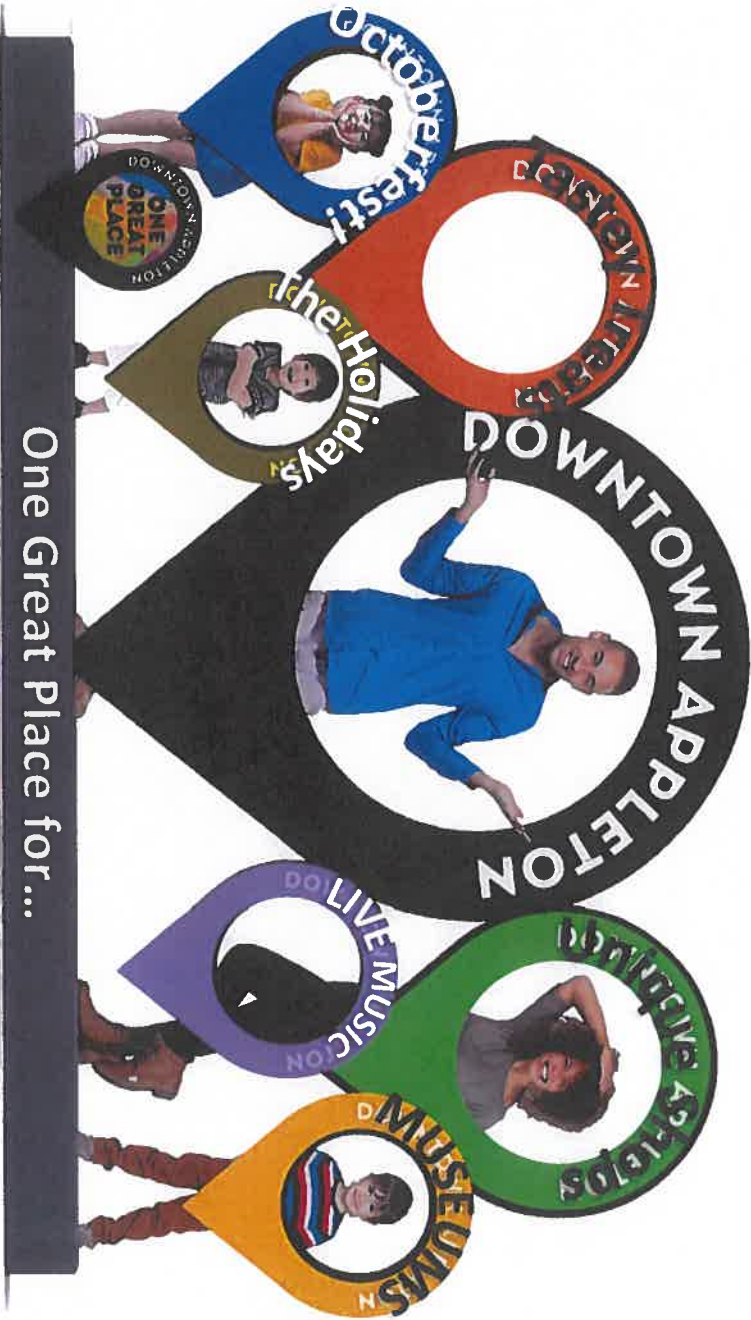

One Great Place for...

APPROXIMATE SCALE

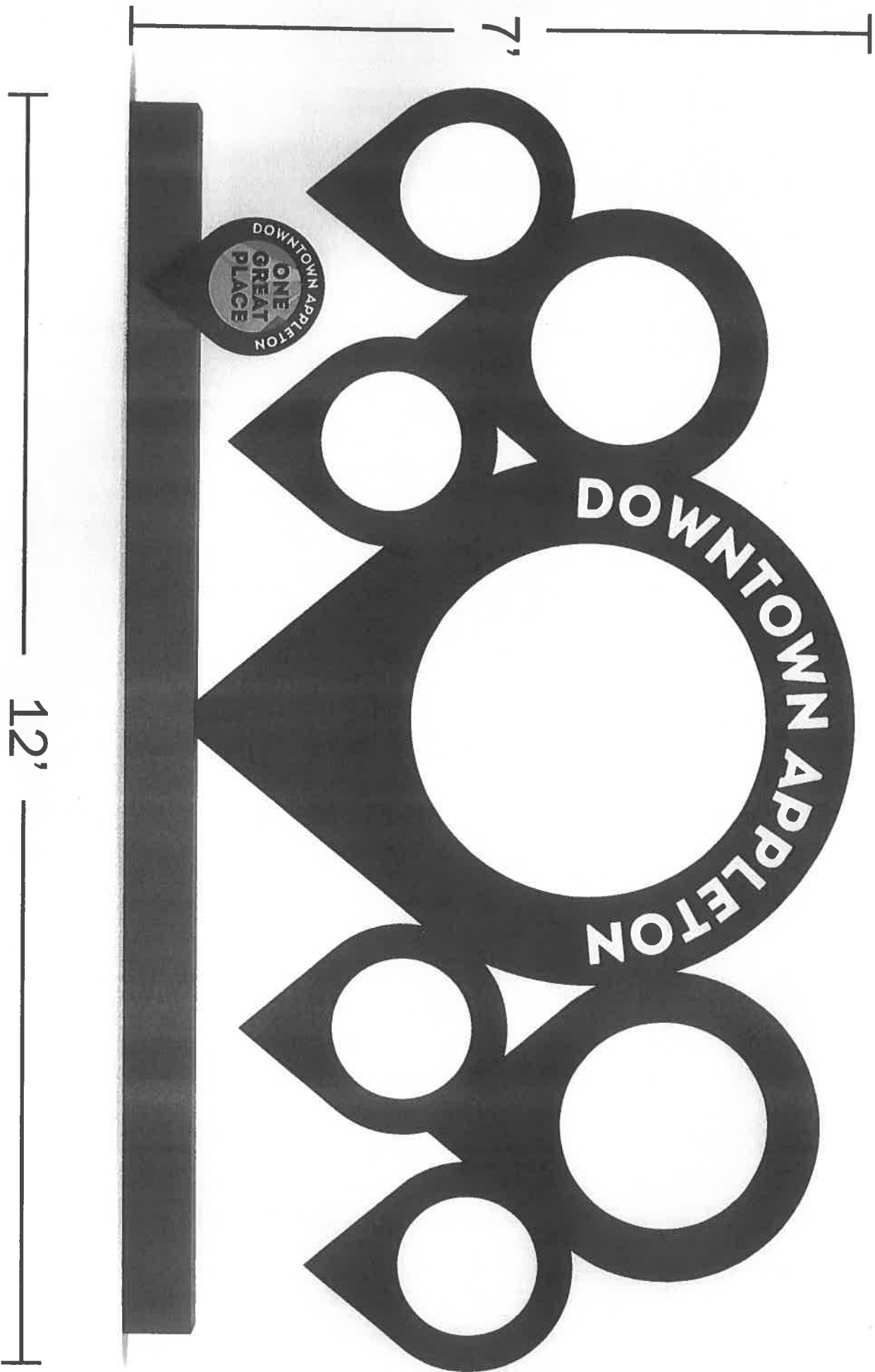

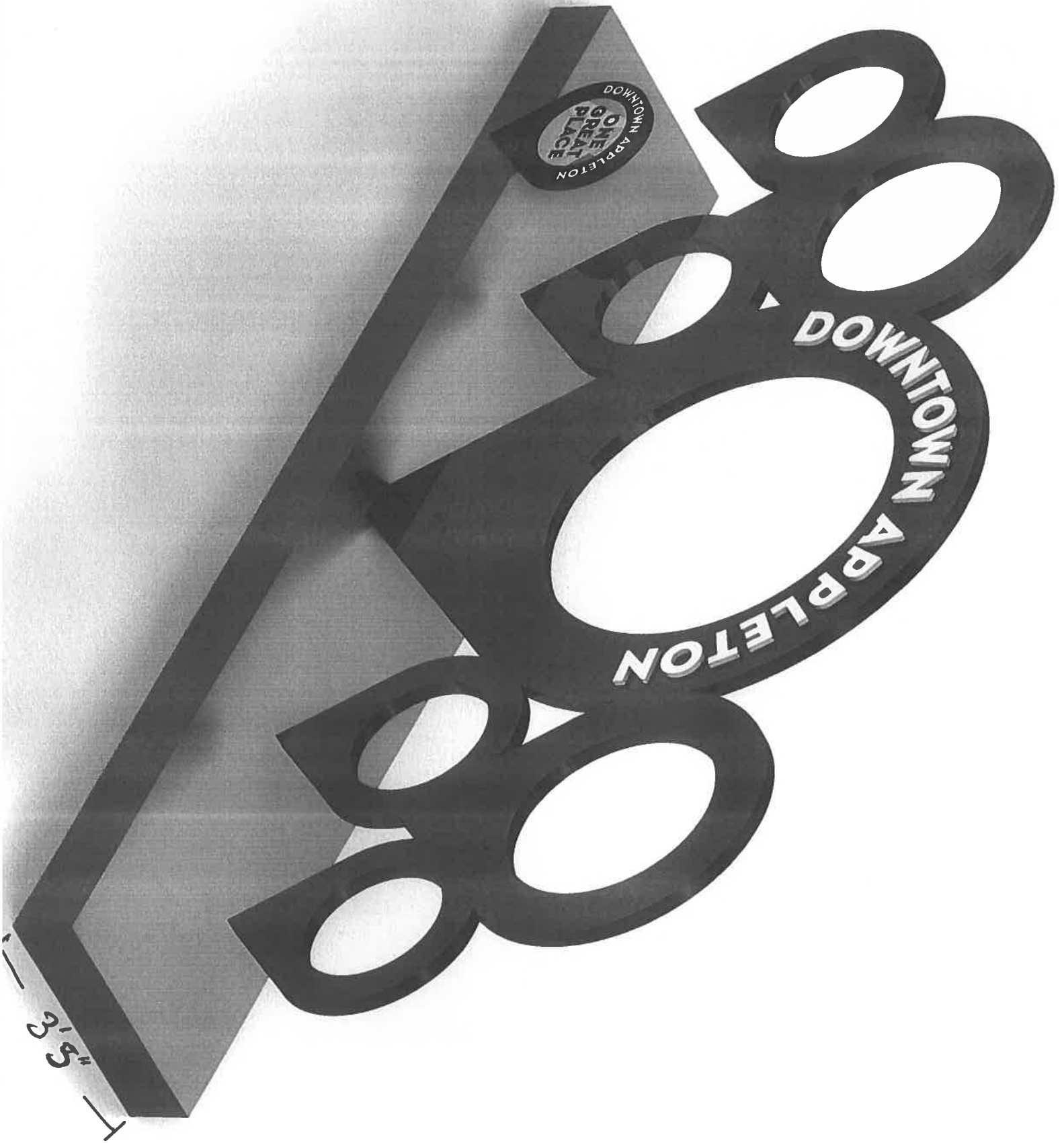

POSSIBLE MATERIAL

Raised Letters

.75" Thick Painted Plate Aluminum

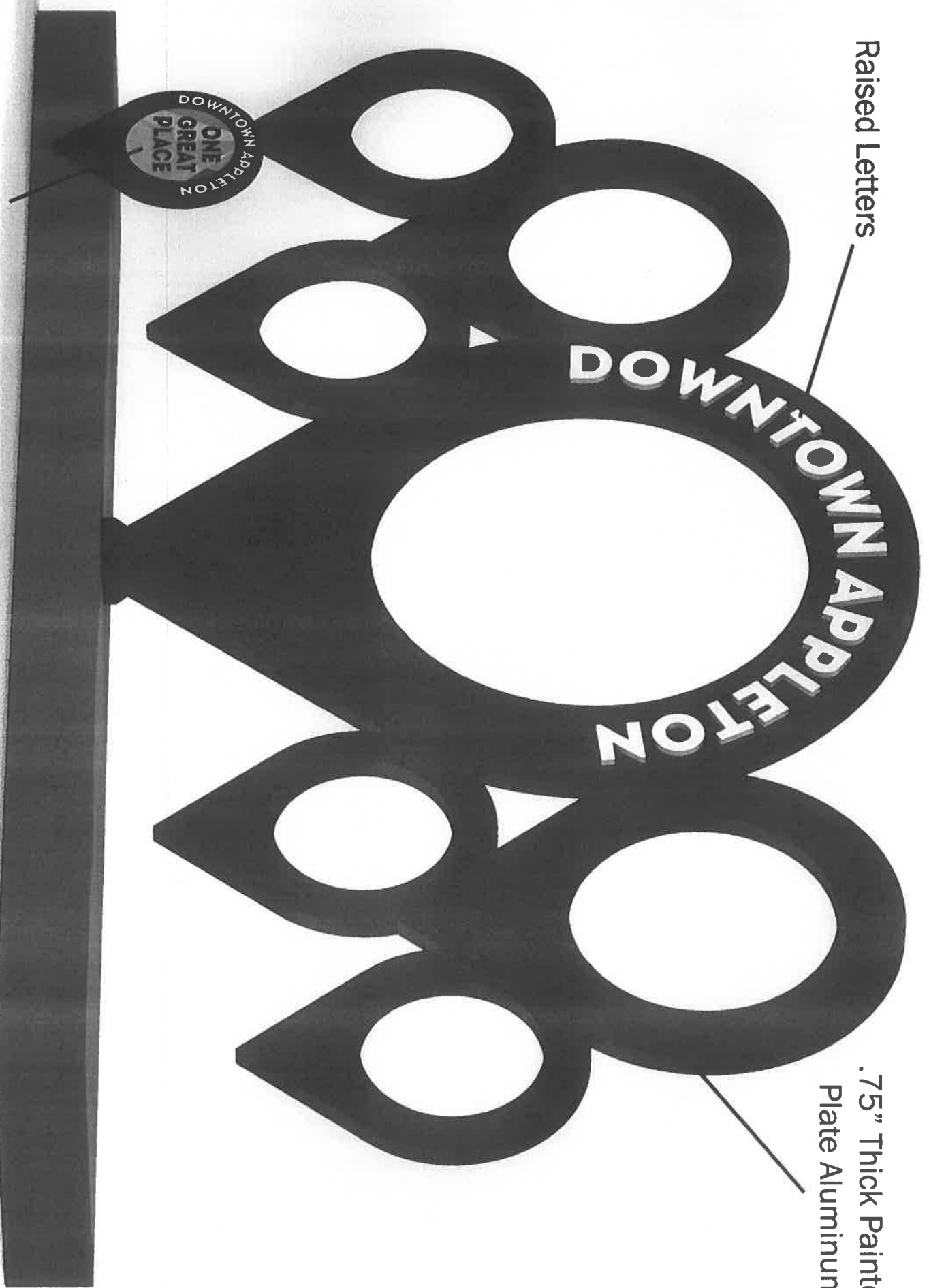

Industrial Decal Atop Plate Aluminum





HOUDINI PLAZA



COLLEGE AVENUE

APPLETON STREET

ONEIDA STREET

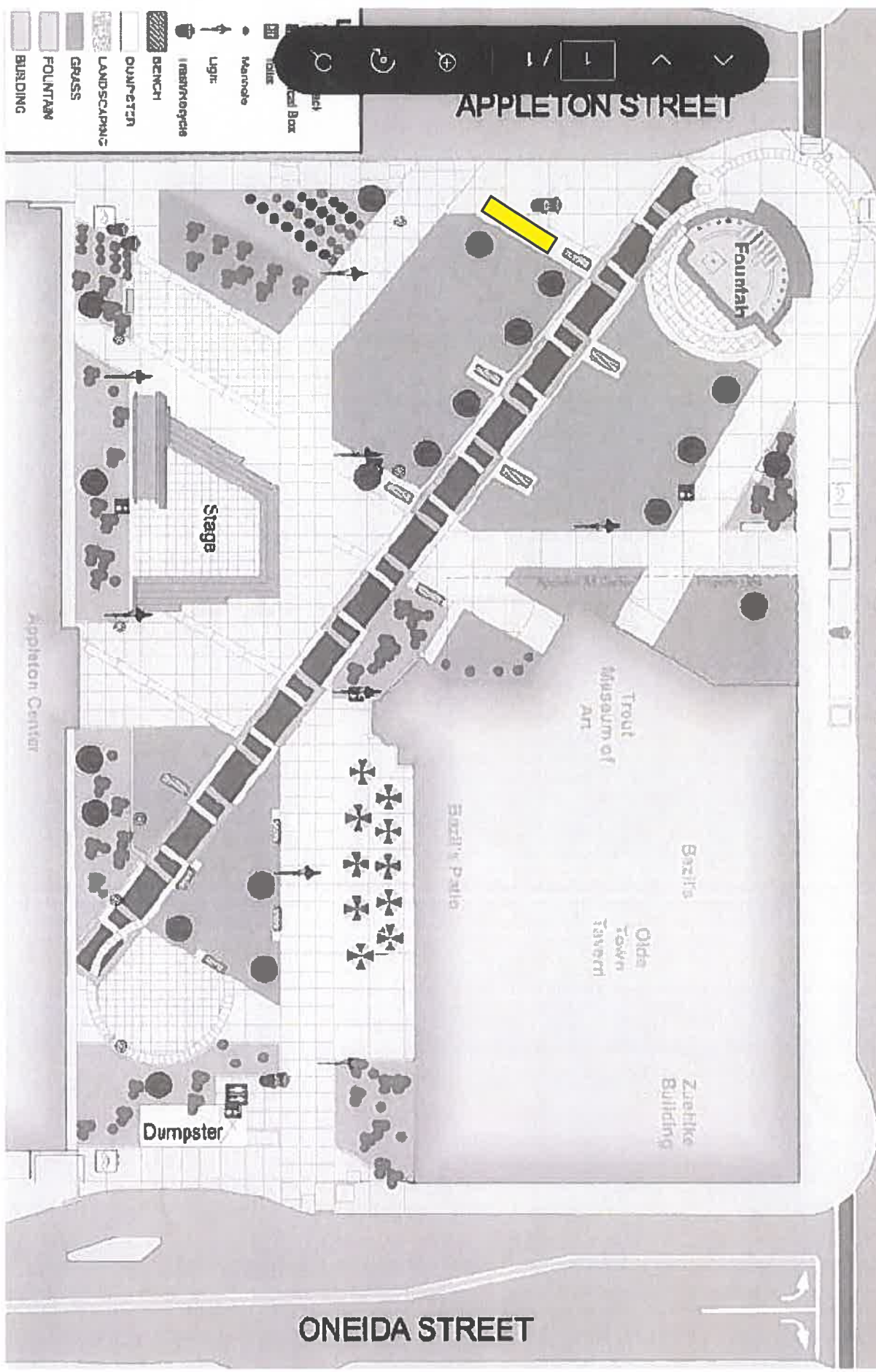

- LANDSCAPING
- GRASS
- FOUNTAIN
- BUILDING

- QUINCE
- BENCH
- LANDSCAPING
- GRASS
- FOUNTAIN
- BUILDING

- MANHOLE
- TOLLS
- Light
- MANHOLE
- TOLLS
- Light

- MANHOLE
- TOLLS
- Light
- MANHOLE
- TOLLS
- Light

- MANHOLE
- TOLLS
- Light
- MANHOLE
- TOLLS
- Light

- MANHOLE
- TOLLS
- Light
- MANHOLE
- TOLLS
- Light

- MANHOLE
- TOLLS
- Light
- MANHOLE
- TOLLS
- Light

- MANHOLE
- TOLLS
- Light
- MANHOLE
- TOLLS
- Light

- MANHOLE
- TOLLS
- Light
- MANHOLE
- TOLLS
- Light

- MANHOLE
- TOLLS
- Light
- MANHOLE
- TOLLS
- Light

DOWNTOWN BRIGHTS COLOR PALETTE



BLUE
CMYK: 100, 20, 0, 0
RGB: 0, 149, 218



YELLOW
CMYK: 0, 20, 100, 0
RGB: 255, 203, 5



GREEN
CMYK: 50, 0, 100, 0
RGB: 141, 198, 63



DEEP TEAL
CMYK: 50, 100, 0, 0
RGB: 146, 39, 143



RED
CMYK: 0, 90, 65, 0
RGB: 239, 64, 80



ORANGE
CMYK: 0, 70, 100, 0
RGB: 243, 112, 33

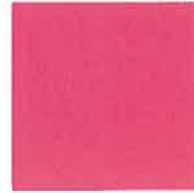

MAGENTA
CMYK: 0, 90, 0, 0
RGB: 238, 61, 150



BLACK
CMYK: 0, 0, 0, 100
RGB: 0, 0, 0



RICH BLACK
CMYK: 30, 30, 30, 100
RGB: 0, 0, 0



WHITE
CMYK: 0, 0, 0, 0
RGB: 255, 255, 255



GREAT FOOD

DOWNTOWN APPLETON

BEER

GREAT ART

FRIENDLY FOLKS

FAMILY FUN

MUSIC

**DOWNTOWN APPLETON
ONE
GREAT
PLACE**

I'M HERE FOR THE...



GREAT FOOD

DOWNTOWN APPLETON

BEER

GREAT ART

FRIENDLY FOLKS

FAMILY FUN

MUSIC

DOWNTOWN APPLETON
ONE GREAT PLACE

I'M HERE FOR THE...



GREAT FOOD

DOWNTOWN APPLETON

BEER

GREAT ART

FRIENDLY FOLKS

FAMILY FUN

DOWNTOWN APPLETON
ONE GREAT PLACE

MUSIC

I'M HERE FOR THE...



EXPLODED VIEW SCULPTURE



PAINTED PLATE
ALUMINUM 1/4"

ONE PIECE PAINTED PLATE ALUMINUM 3/4"

GREAT FOOD

GREAT ART

INDUSTRIAL DECAL

FRIENDLY FOLKS

INDUSTRIAL DECAL

BOLTS FOR ATTACHING TO
LARGE CLACK CENTER "PIN"

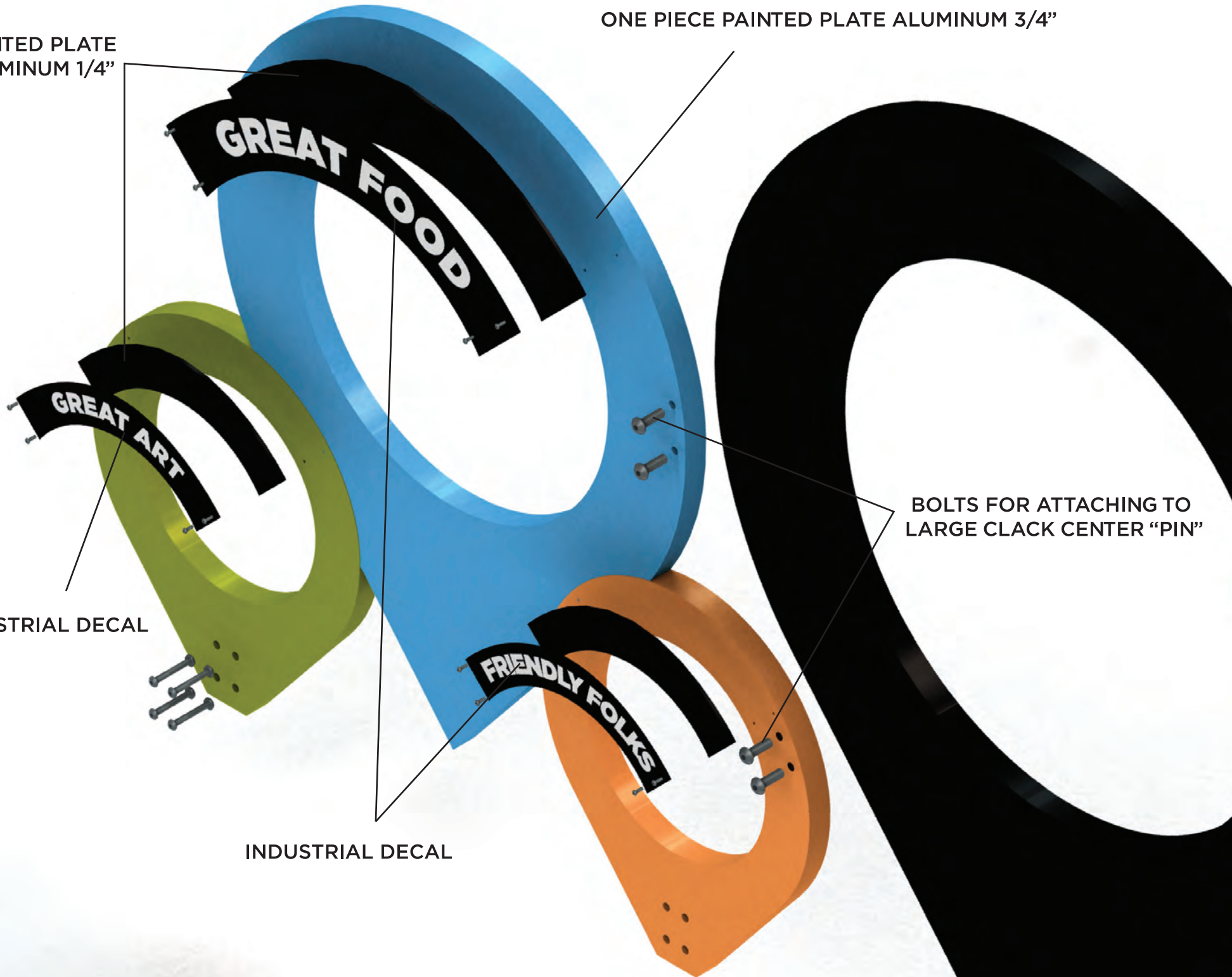

INDUSTRIAL DECAL

PAINTED PLATE ALUMINUM 3/4"



FABRICATED BRACKETS
ALUMINUM 1/4"

PAINTED PLATE ALUMINUM 1/4"

PAINTED PLATE
ALUMINUM 1/4"

INDUSTRIAL DECAL

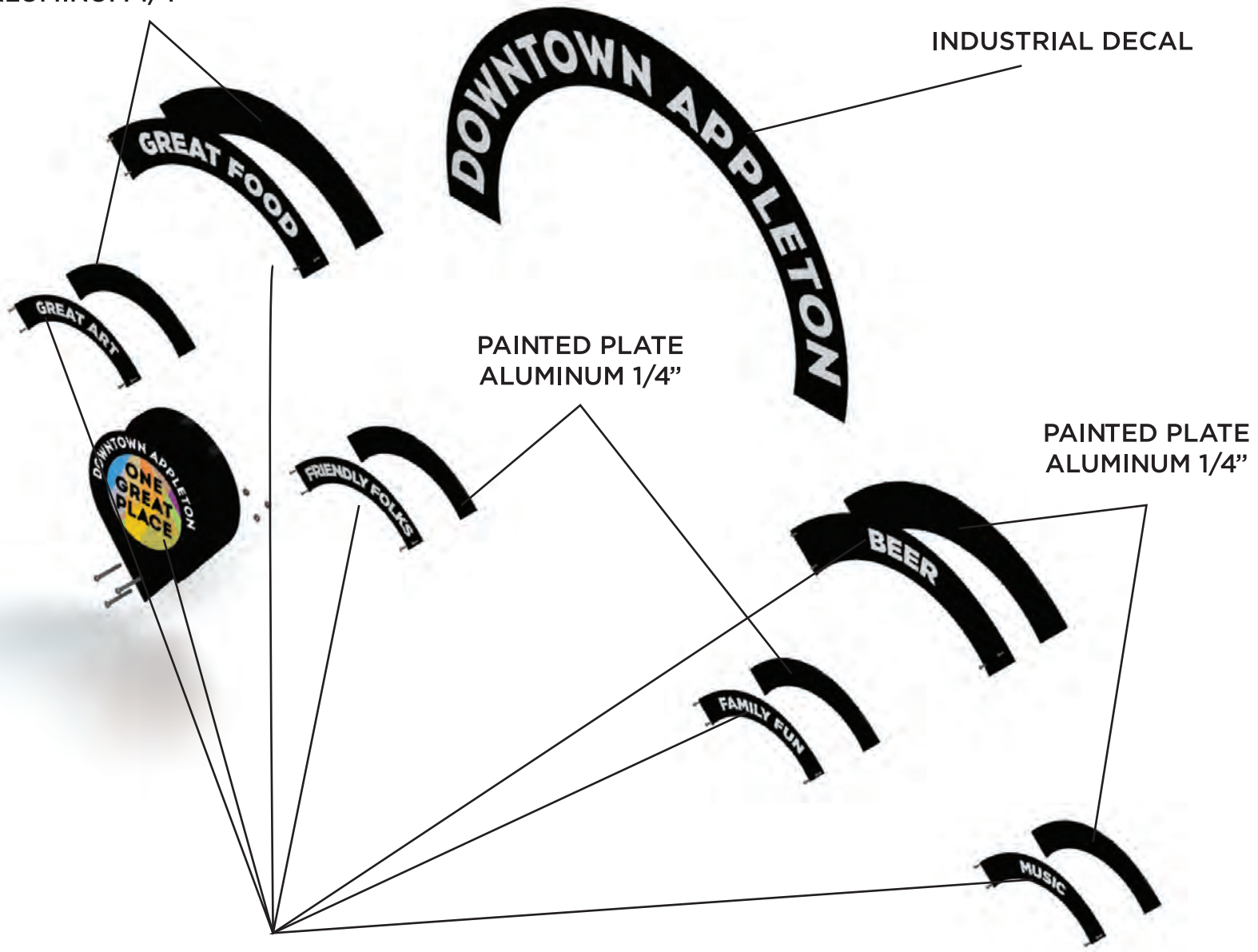

PAINTED PLATE
ALUMINUM 1/4"

PAINTED PLATE
ALUMINUM 1/4"

INDUSTRIAL DECAL

PAINTED PLATE ALUMINUM 3/4"

ONE PIECE
PAINTED
TO LOOK
LIKE THREE

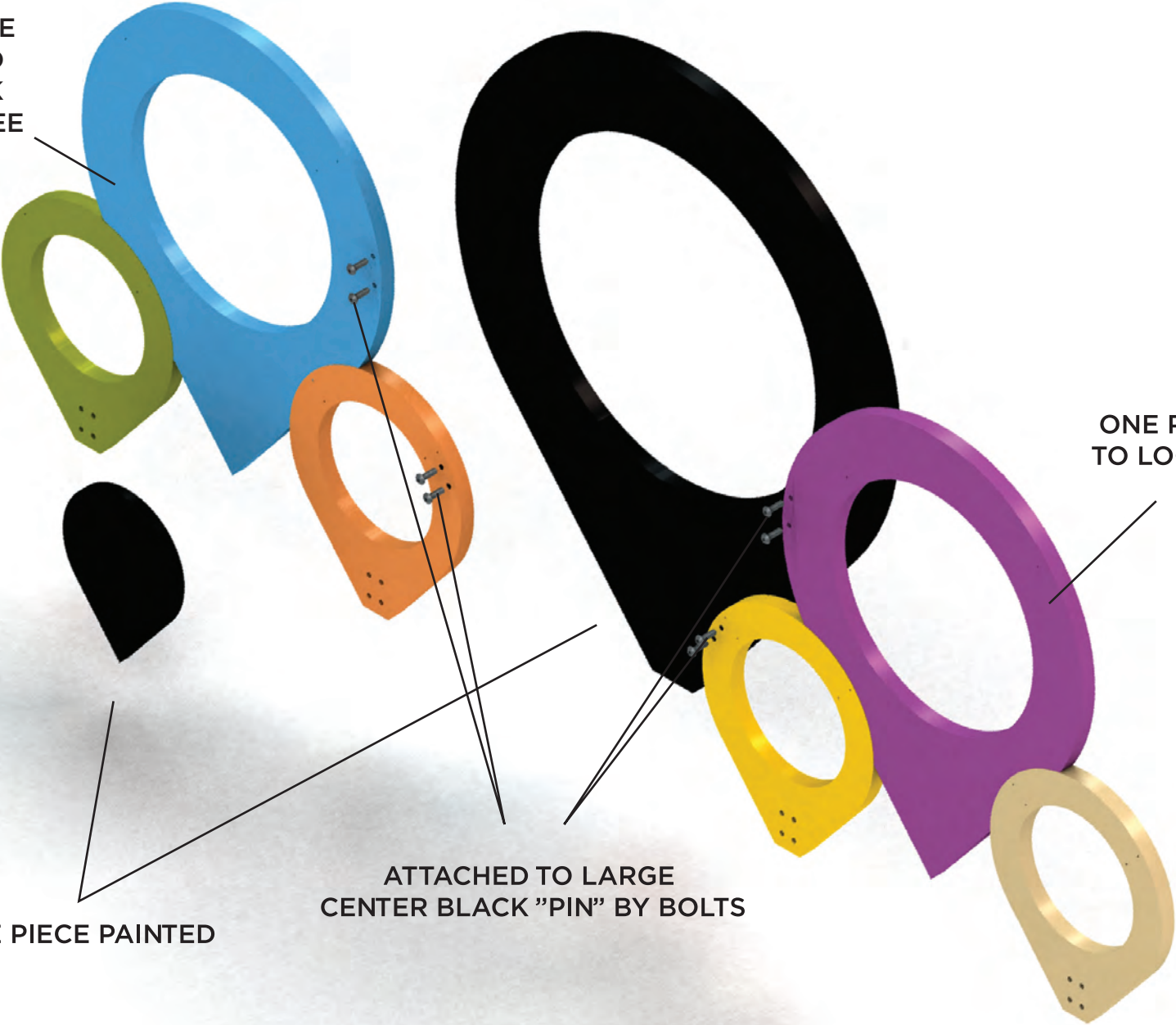

ONE PIECE PAINTED
TO LOOK LIKE THREE

ONE PIECE PAINTED

ATTACHED TO LARGE
CENTER BLACK "PIN" BY BOLTS

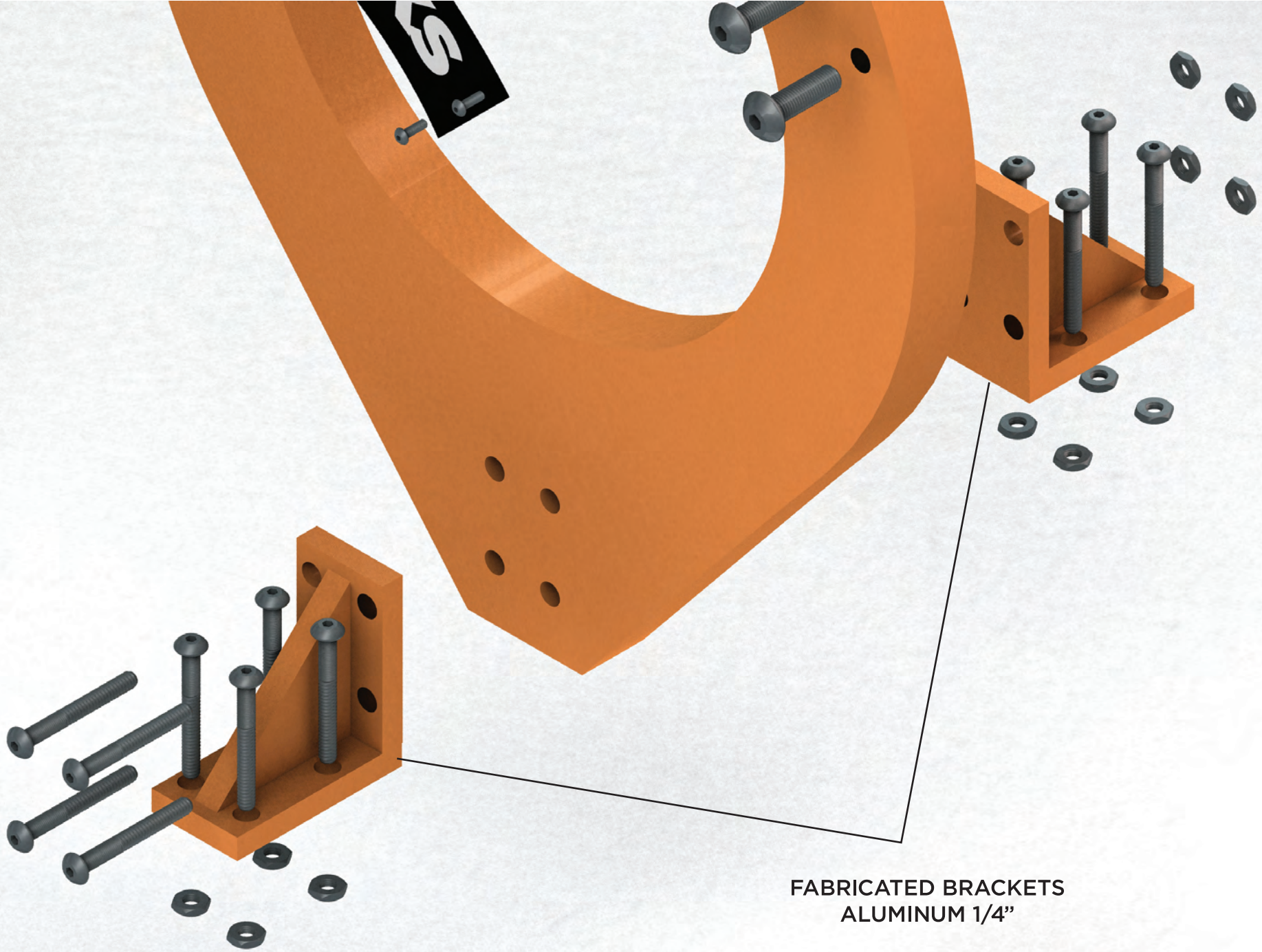

FABRICATED BRACKETS
ALUMINUM 1/4"

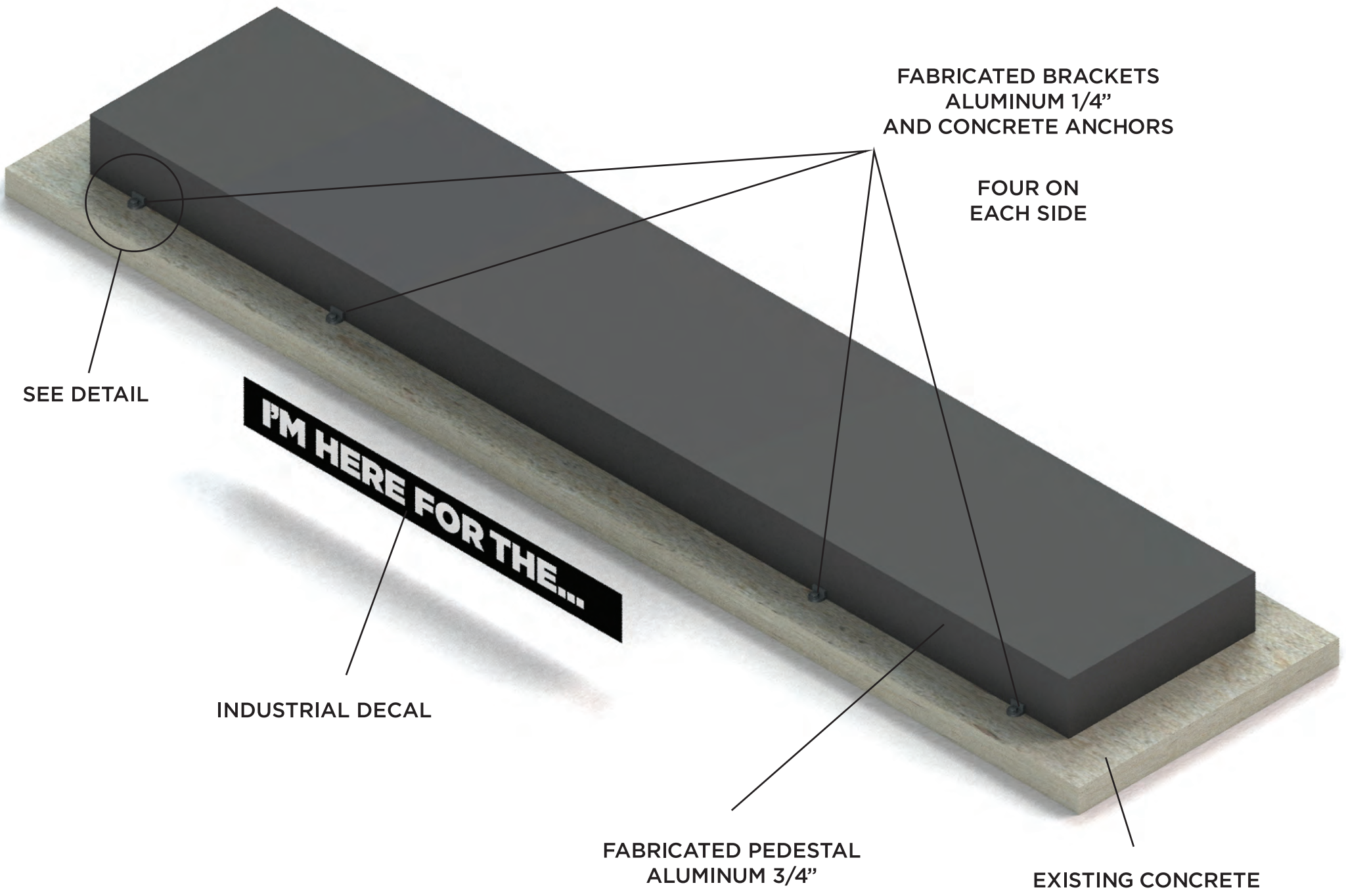

FABRICATED BRACKETS
ALUMINUM 1/4"
AND CONCRETE ANCHORS

FOUR ON
EACH SIDE

SEE DETAIL

I'M HERE FOR THE...

INDUSTRIAL DECAL

FABRICATED PEDESTAL
ALUMINUM 3/4"

EXISTING CONCRETE

1/2" x 5-1/2" Red Head Trubolt
Hot-Dipped Galvanized

FABRICATED BRACKETS
ALUMINUM 1/4"
AND CONCRETE ANCHORS

WELDED
TO PEDESTAL

EXISTING CONCRETE

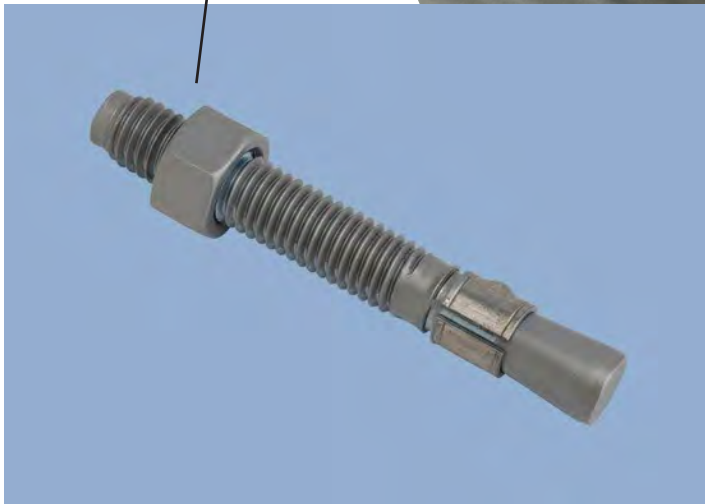
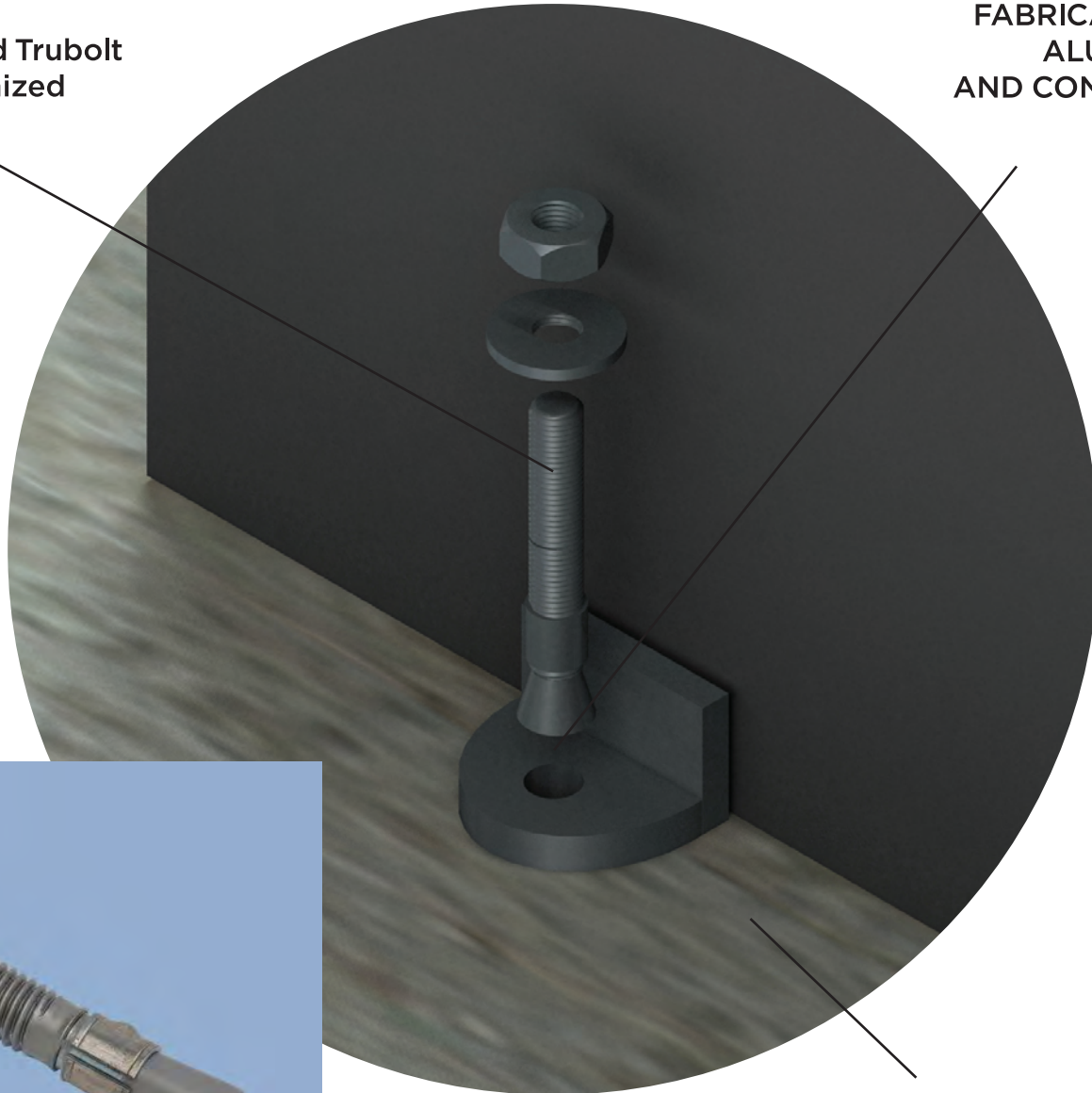

SCALE

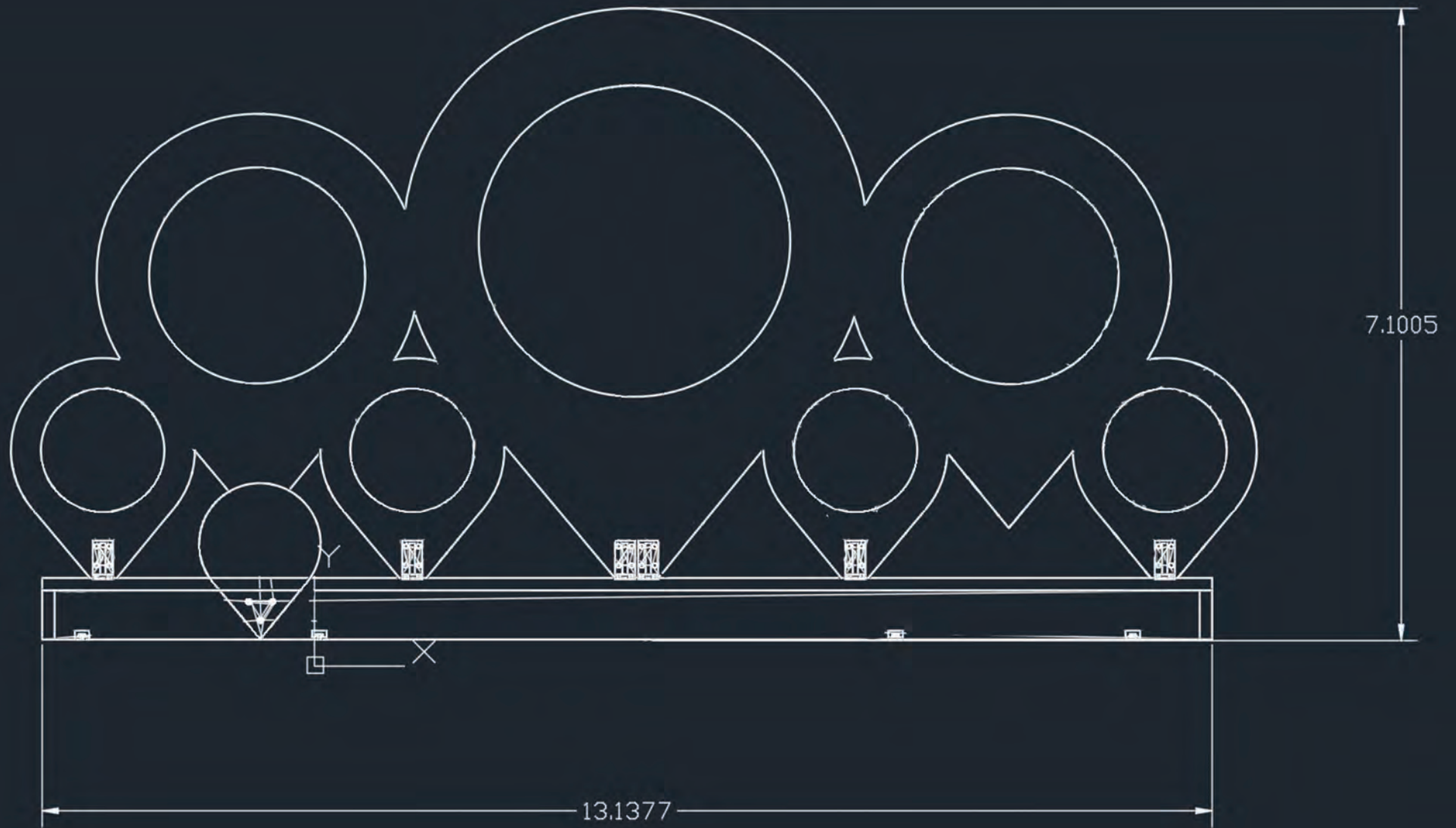



CITY OF APPLETON

Date: February 5th, 2025

To: Members of the Common Council

From: Mayor Jacob A. Woodford 

Subject: Confirmation of Appointments

It is with pleasure that I present the following recommendations for your confirmation at the February 5th, 2025, Common Council meeting.

Appleton Public Art Committee – Appointment

Jake Jeffery Bauer Term Ends December 2028

Jake is a multifaceted artist and entrepreneur with a technical degree in Welding and Metal Fabrication from Bay College. As the owner of Light Craft Events, he specializes in event lighting design, creating unforgettable atmospheres. Additionally, as the founder of 4th Wall Productions, he brings art to life at events through live art performances, blending creativity with audience engagement.

With a strong background in welding, CNC laser engraving, router cutting, woodworking, and metalworking, Jake seamlessly merges technical precision with artistic vision. His skills extend to graphic design, lighting design, video editing, and industry networking, making him a versatile force in both the creative and technical realms. Whether crafting intricate designs or illuminating events with dynamic visuals, Jake is passionate about sharing the arts with our community.